

HCT63

CONDUCTIVITY TRANSMITTER

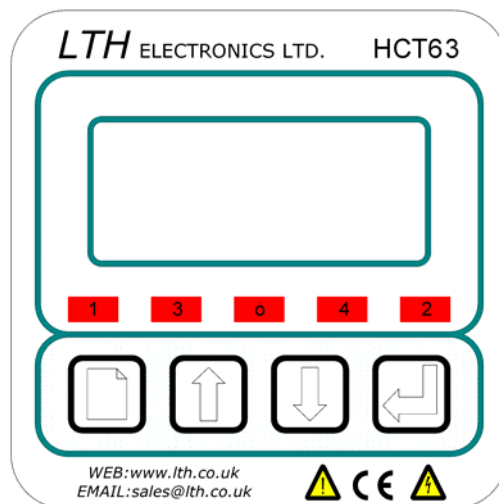

OPERATION GUIDE

PREFACE

Product warranty

The HCT63 has a warranty against defects in materials and workmanship for three years from the date of shipment. During this period LTH will, at its own discretion, either repair or replace products that prove to be defective. The associated software is provided 'As is' without warranty.

Limitation of warranty

The foregoing warranty does not cover damage caused by accidental misuse, abuse, neglect, misapplication or modification.

No warranty of fitness for a particular purpose is offered. The user assumes the entire risk of using the product. Any liability of LTH is limited exclusively to the replacement of defective materials or workmanship.

There are no user serviceable parts, including fuses etc., within the unit. Any attempt to dismantle the instrument will invalidate the warranty.

Disclaimer

LTH Electronics Ltd reserves the right to make changes to this manual or the instrument without notice, as part of our policy of continued developments and improvements.

All care has been taken to ensure accuracy of information contained in this manual. However, we cannot accept responsibility for any errors or damages resulting from errors or inaccuracies of information herein.

Copyright and trademarks

All rights reserved. Translations, reprinting or copying by any means of this manual, complete or in part or in any different form requires our explicit approval.

HCT63 is a trademark of LTH Electronics Ltd

First edition: April 2003 (29-Apr-03)

Document part number: 6145

LTH Electronics Ltd
Chaul End Lane
Luton
Bedfordshire
LU4 8EZ
England

Telephone +44 (0)1582 593693
Fax +44 (0)1582 598036
email sales@lth.co.uk
Web www.lth.co.uk

Manufacturing Standards



Electromagnetic compatibility

This instrument has been designed to comply with the standards and regulations set down by the European EMC Directive

Safety

This instrument has been designed to comply with the standards and regulations set down by the European Low Voltage Directive using BS EN 61010-1 : 1993

Quality

This instrument has been manufactured under the following quality standard: BS EN ISO 9002:1994 (BS 5750 part 2-1987). Certificate No : FM 13843

Note: The standards referred to in the design and construction of LTH products are those prevailing at the time of product launch. As the standards are altered from time to time, we reserve the right to include design modifications that are deemed necessary to comply with the new or revised regulations.

CONTENTS

1	Introduction	1
1.1	About the HCT63	1
1.2	Unit Specification	1
2	Safety & EMC	4
2.1	Wiring Installation.....	4
2.2	Noise suppression	5
3	Installation.....	6
3.1	Head-mounted Version Mechanics	6
3.2	Wall-mounted Version Mechanics	8
3.3	Connections	9
4	User Interface	13
4.1	The Front Panel	13
4.2	The Menu System.....	14
4.3	Unit Configuration	15
4.4	Number entry	16
4.5	Error Messages.....	16
5	Main Display	17
6	Menu Access	18
6.1	Changing the Access Code	18
7	Parameters	19
7.1	Units	19
7.2	Cell Constant	20
7.3	Range.....	20
7.4	Temperature Input	20
7.5	Simulated Inputs	21
8	Set Point Relays	22
8.1	Set Point Source	23
8.2	Set Point Range.....	23
8.3	Set Point Trigger	23
8.4	Set Point Mode	24
8.5	Dose Alarm Timers	25
8.6	USP26 Operation.....	25
8.7	Alarms.....	26
9	Current Output	27
9.1	Input	27

Preface

9.2	Select Output	27
9.3	Output Range, Zero & Span	28
9.4	Proportional Control	28
9.5	Error Condition	28
10	Calibration	29
10.1	On-Line/Off-Line Operation	29
10.2	Sensor Calibration	29
10.3	Temperature Calibration	30
10.4	Cell Constant Adjustment	30
10.5	Current Output Calibration	30
10.6	Resetting the User Calibration	31
11	Save/Restore	31
12	Configuration	32
12.1	Language	32
12.2	Temperature Input Sensor	32
12.3	Error Messages	33
12.4	Input Filtering (Averaging)	33
12.5	Bargraph	33
12.6	Software Version	33
13	Fault Finding	34
14	Guarantee and Service	38
15	Appendix A – Factory Default Setups	40
16	Appendix B – Customer Setup	43
17	Appendix C - Calibration	45
17.1	Best Practice for Fine Tuning the HCT63	45
17.2	Calibration of Conductivity or Resistivity Readings	45
17.3	Resistance calibration of the instrument only	45
17.4	Calibration with Standard Solutions	46
17.5	Calibration by Comparison with Another Instrument	46
17.6	Calibration of the Cell Constant	46
17.7	Care and Maintenance of Conductivity Sensors	47
17.8	Installation and Choice of Conductivity Sensors	47
17.9	Table of calibration resistance values	49
18	Appendix D – Ultra Pure Water	50
19	Appendix E – Temperature Coefficient	52
19.1	Calculating the temperature coefficient of a solution	52

Preface

20	Appendix F – Temperature Data	53
21	Appendix G – Save / Restore	54
21.1	Saving and Restoring Set-up Data.....	54
22	Appendix H – Error Messages	55
23	Index	58

GLOSSARY

LCD	Liquid crystal display
LED	Light Emitting Diode
LSB	Least Significant Bit
mS	MilliSiemens
μ S	MicroSiemens
MSB	Most Significant Bit
ppm	Parts per million.
ppt	Parts per thousand
PRT	Platinum Resistance Thermometer.
PSD	Programmable System Devices.
RTD	Resistive Temperature Device
SP	Set point.
TDS	Total Dissolved Solids
USP	United States Pharmacopia specification.

1 Introduction

1.1 About the HCT63

The HCT63 is a microprocessor controlled conductivity measurement instrument with the facility to display in $\mu\text{S}/\text{cm}$, mS/cm , $\text{M}\Omega.\text{cm}$ or ppm. The unit utilises a multifunction LCD to display readings and provide feedback to the operator. It is available with different options to provide fully configurable control and feedback with up to two control relays and two 0/4-20mA current output sources.

1.2 Unit Specification

Conductivity sensor	Two LTH conductivity cells are available for head-mounting the instrument: CMC64/10/PT43 This has a cell constant of 1.0 and is typically used in waste water measurement. CMC68/001/PT43 This has a cell constant of 0.01 and is typically used for ultra-pure water measurement.
Ranges of measurement	0 - 0.999 $\mu\text{S}/\text{cm}$ to 0 - 99.99 mS/cm (K= 0.01 to 1.0) 0 - 99.99 $\text{K}\Omega.\text{cm}$ to 0 - 99.99 $\text{M}\Omega.\text{cm}$ (K= 0.01 to 1.0). 0 - 0.999 ppm to 0 - 99.99 ppt. (parts per thousand). See the following range / cell constant table.
Conductivity accuracy	0.5 % of range
Linearity	0.1 % of range
Repeatability	0.1 % of range
Operator adjustment (conductivity)	± 10 % slope (gain) adjustment for solution calibration.
Temperature sensor	Pt 1000 RTD.
Range of temperature measurement	-50 °C to +300 °C (-58 °F to 572 °F) for full specification.
Temperature accuracy	0.2 °C
Operator adjustment (temperature)	± 50 °C or ± 122 °F
Range of temperature compensation	-10 °C to +130 °C (14 °F to 266 °F) for full specification.
Temperature compensation type	Fixed UPW curve plus variable slope 0 - 3.9 % / °C over -10 to +110 °C. Selectable In or Out.
Temperature compensation base	Selectable at 20 or 25 °C.
Cell constant adjustment	Fully adjustable from 0.01 - 19.99.
Cell Constant Calibration	Only available on K = 0.1 and 0.01 $\pm 50\%$
Remote range changing	Using a 3 pole 8 way remote mounted switch. Connection by up to 100 metres of cable.

Introduction

Off-line facility (for calibration and commissioning)	The relays are de-energised and the current output is held at the last on-line value.
Ambient operating temperature	-20 °C to +50 °C (-4 °F to 122 °F) for full specification.
Ambient temperature variation	0.01% of range / °C (typical)
Display	Custom back-lit LCD module. 4 character (& sign) 7 segment (20 mm high) for measure value; 2x3 dot matrix for units indication; and 1x16 dot matrix for information and programming.
Digital Inputs	Three digital inputs (contact closure) for remote selection of measurement range.
Current output (1 standard, 2 optional)	Each selectable 0 - 20 mA or 4 – 20 mA into 750 ohms max., fully isolated to 2kV. Expandable up to 5% of any operating range and offset anywhere in that range.
Operator adjustment (Current output)	± 1 mA zero and ± 1 mA span for remote monitor calibration.
Setpoints and control relays (2 optional)	Fully configurable setpoints (µS, ppm, mS, MΩ, °C) with volt free contacts for each relay. Rated at 5A 30V DC / 5A 250V AC (non-inductive). Red LED's indicate relay energised.
Operating modes (Control relays 1 and 2)	On/Off, Time proportioning, Pulse proportioning and Band modes selectable for each relay. Adjustable delay timer up to 10:00 mm:ss in the On/Off mode. Hysteresis 0 to 9.9% in the On/Off mode. Adjustable dose alarm timer up to 15:00 mm:ss in all modes. Adjustable cycle time and proportional band in the proportional modes.
Alarm mode	USP26 settings with optional pre-trigger. Either relay can be set to energise on any of the following instrument conditions: Sensor alarm, Dose alarm, Calibration, Off line, Any error.
Switches	Four tactile-feedback push buttons.
EMC : Immunity	BS EN 50082-2:1995.
EMC :Emissions	BS EN 50081-1:1992.
LVD : Safety standard	BS EN 61010-1:1993.
Power supply	15 – 30V AC or DC @ 200 mA.
Head Mount Housing	Conductive ABS blue plastic, rated IP66.
Weight	600 grams (instrument only).
Dimensions	110 x 116 x 145 mm (H, W, D) excluding connectors.

1.2.1 Range & Sensor Compatibility Tables

Conductivity range	Nominal cell constant		
	0.010	0.100	1.000
0 to 0.999 $\mu\text{S}/\text{cm}$	✓	✗	✗
0 to 9.999 $\mu\text{S}/\text{cm}$	✓	✓	✗
0 to 99.99 $\mu\text{S}/\text{cm}$	✓	✓	✓
0 to 999.9 $\mu\text{S}/\text{cm}$	✗	✓	✓
0 to 9.999 mS/cm	✗	✗	✓
0 to 99.99 mS/cm	✗	✗	Note 1

Resistivity range	Nominal cell constant		
	0.010	0.100	1.000
0 to 99.99 $\text{k}\Omega\text{-cm}$	✗	✓	✓
0 to 999.9 $\text{k}\Omega\text{-cm}$	✓	✓	✗
0 to 9.999 $\text{M}\Omega\text{-cm}$	✓	✓	✗
0 to 99.99 $\text{M}\Omega\text{-cm}$	✓	✗	✗

Total dissolved solids range	Nominal cell constant		
	0.010	0.100	1.000
0 to 0.999 ppm	✓	✗	✗
0 to 9.999 ppm	✓	✓	✗
0 to 99.99 ppm	✓	✓	✓
0 to 999.9 ppm	✗	✓	✓
0 to 9999 ppm	✗	✗	✓
0 to 99.99 ppt	✗	✗	✓

Note 1: Maximum measurement range will be limited by solution temperature. With temperature compensation slope set to 2%/°C derate linearly from full scale at 25°C to 50% of scale at 100°C.

Note 2: Total Dissolved Solids in ppm = $\mu\text{S}/\text{cm} * F$,
where F = TDS Factor (0.50 - 0.90)

2 Safety & EMC

This chapter describes how to install and mount the panel-mounting and surface-mounting versions, and how to connect the unit to a power source and auxiliary equipment.

Although today's electronic components are very reliable, it should be anticipated in any system design that a component could fail and it is therefore desirable to make sure a system will **fail safe**. This could include the provision of an additional monitoring device, depending upon the particular application and any consequences of an instrument or sensor failure.

2.1 Wiring Installation

The specified performance of the HCT63 is entirely dependent on correct installation. For this reason, the installer should thoroughly read the following instructions before attempting to make any electrical connections to the unit.

WARNING! : ALWAYS REMOVE THE MAIN POWER FROM THE SYSTEM BEFORE ATTEMPTING ANY ALTERATIONS TO THE WIRING. ENSURE THAT BOTH POWER INPUT LINES ARE ISOLATED. MAKE SURE THAT THE POWER CANNOT BE SWITCHED ON BY ACCIDENT WHILST THE UNIT IS BEING CONNECTED. FOR SAFETY REASONS AN EARTH CONNECTION MUST BE MADE TO THE EARTH TERMINAL OF THIS INSTRUMENT.

ADHERE STRICTLY TO LOCAL WIRING AND SAFETY REGULATIONS WHEN INSTALLING THIS UNIT. SHOULD THESE REGULATIONS CONFLICT WITH THE FOLLOWING INSTRUCTIONS, CONTACT LTH ELECTRONICS OR AN AUTHORISED LOCAL DISTRIBUTOR FOR ADVICE.

To maintain the specified levels of Electro Magnetic Compatibility (EMC, susceptibility to and emission of electrical noise, transients and radio frequency signals) it is essential that the types of cables recommended within these instructions be used. If the installation instructions are followed carefully and precisely, the instrument will achieve and maintain the levels of EMC protection stated in the specification. Any equipment to which this unit is connected must also have the same or similar EMC control to prevent undue interference to the system.

- ◆ Terminations at the connectors should have any excess wire cut back so that a minimal amount of wire is left free to radiate electrical pick-up inside or close to the instrument housing.
- ◆ The terminal cover of the surface mount unit must be correctly re-assembled and securely fastened, to maintain a continuous electro-magnetic shield around the instrument.

Note: The use of CE marked equipment to build a system does not necessarily mean that the completed system will comply with the European requirements for EMC.

2.2 Noise suppression

In common with other electronic circuitry, the HCT63 may be affected by high level, short duration noise spikes arising from electromagnetic interference (EMI) or radio frequency interference (RFI). To minimise the possibility of such problems occurring, the following recommendations should be followed when installing the unit in an environment where such interference could potentially occur.

The following noise generating sources can affect the HCT63 through capacitive or inductive coupling.

- ◆ Relay coils
- ◆ Solenoids
- ◆ AC power wires, particularly at or above 100V AC
- ◆ Current carrying cables
- ◆ Thyristor field exciters
- ◆ Radio frequency transmissions
- ◆ Contactors
- ◆ Motor starters
- ◆ Business and industrial machines
- ◆ Power tools
- ◆ High intensity discharge lights
- ◆ Silicon control rectifiers that are phase angle fired

The HXT63 series is designed with a high degree of noise rejection built in, to minimise the potential for interference from these sources, but it is recommended that you apply the following wiring practices as an added precaution. Cables transmitting low level signals should not be routed near contactors, motors, generators, radio transmitters, or wires carrying large currents.

If noise sources are so severe that the instrument's operation is impaired, or even halted, the following external modifications should be made, as appropriate:

- ◆ Fit arc suppressors across active relay or contactor contacts in the vicinity.
- ◆ Run signal cables inside steel tubing as much as is practical.
- ◆ Use the internal relays to switch external slave relays or contactors when switching heavy or reactive loads.
- ◆ Fit an in-line mains filter close to the power terminals of the supply.
- ◆ In cases of very high background RF and HF noise environments, LTH can supply a length of proprietary RF suppressing mains cable.

3 Installation

3.1 Head-mounted Version Mechanics

This version of the HCT63 is designed for mounting on a pipe T-piece with the sensor in the main current flow.

Figure 1 shows the dimensions of the components required for installation.

Figure 2 shows the dimensions of the completed assemblies.

The two cells are physically similar.

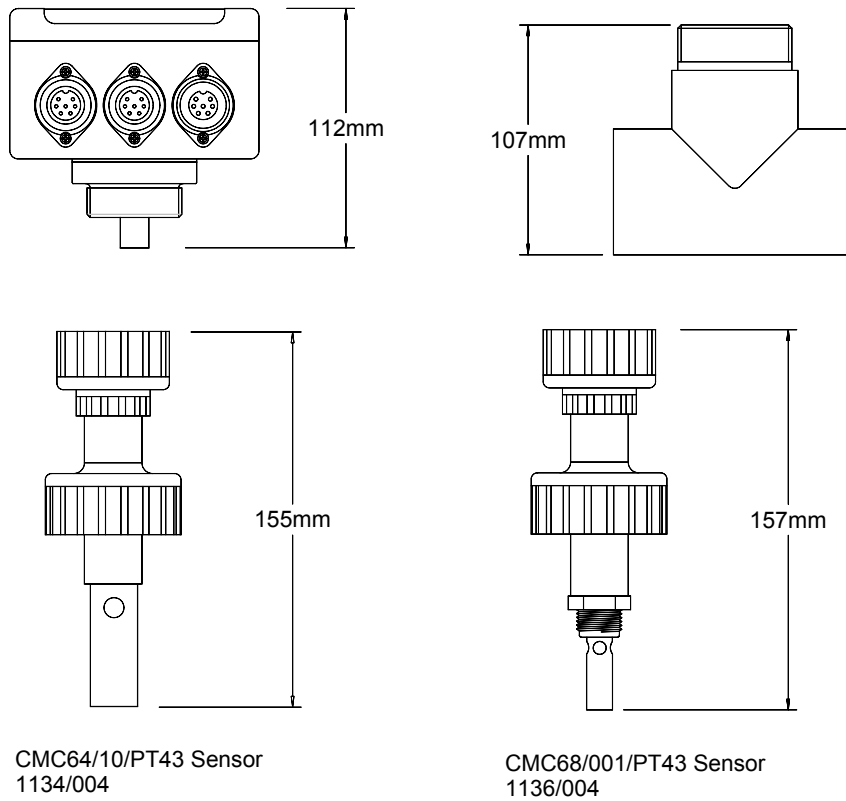

Figure 1 Head-mounting Installation components

Installation

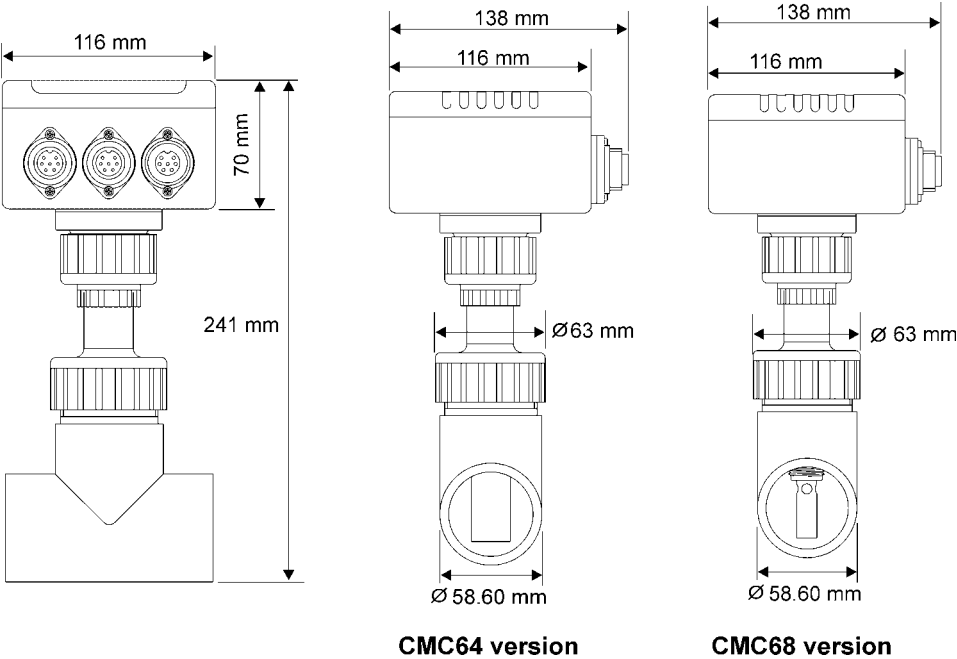

Figure 2 Head-mounting component dimensions

3.2 Wall-mounted Version Mechanics

This version is mounted on a wall and connects to sensors via a (maximum) 10m cable. Figure 3 shows the dimensions and fixing points of the unit.

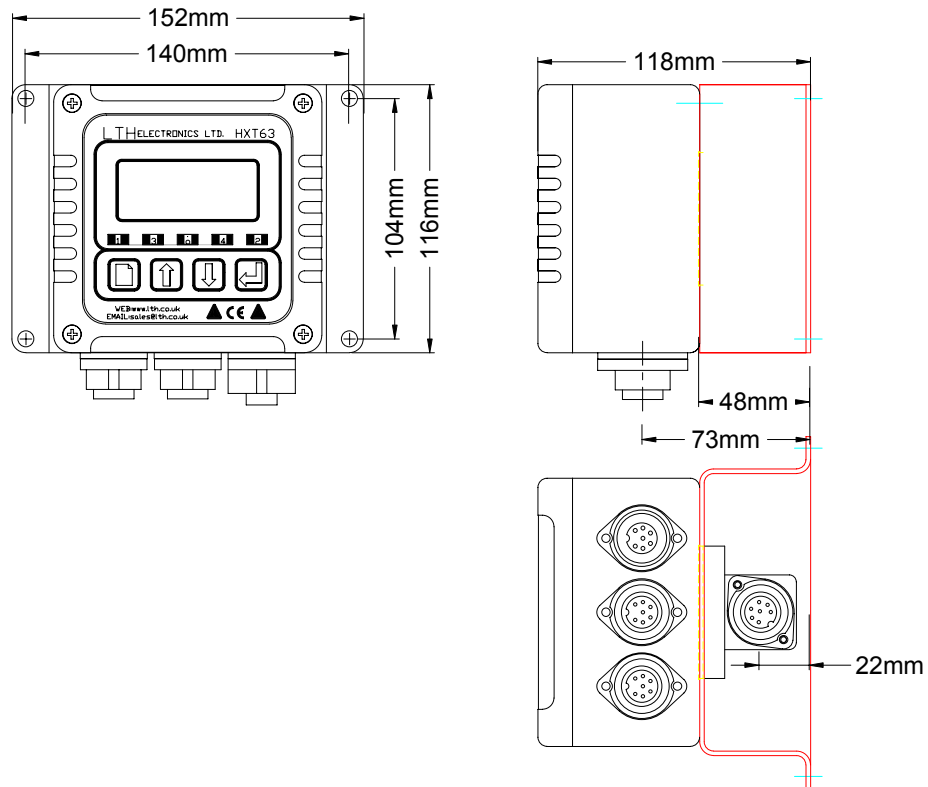

Figure 3 Wall-mounted unit dimensions

3.3 Connections

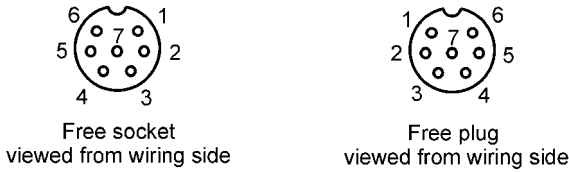
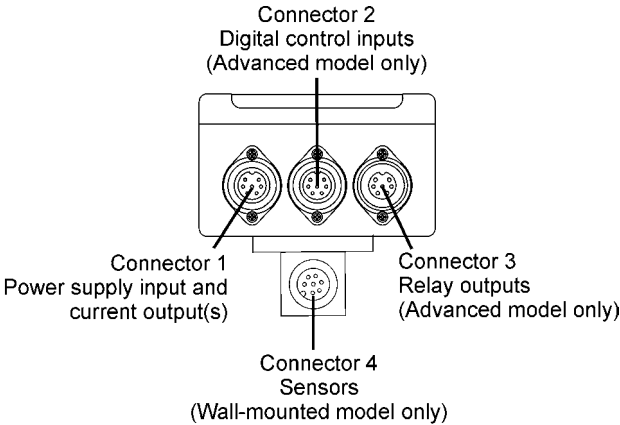

Figure 4 : Panel mount unit, rear view

Connections to the unit are made via the three circular connectors on the side of the unit plus an underside connector for the wall-mounted version. The connections are as follows:

Connector 1 Free male socket
Power supply input and current outputs

Pin	Function
1	Common 0V
2	24V supply
3	Current A output
4	Current B output (Advanced version only)
5	Not used
6	Not used
7	Earth – Connect to power supply earth*

*Note: Connect Connector 1 Pin 7 Earth back to the power supply earth to ensure electrical circuits are shielded.

Installation

Connector 2 Free male socket
Digital range selection inputs (advanced version only)

Pin	Function
1	Digital input - common
2	Not used
3	Not used
4	Digital input 3
5	Digital input 1
6	Digital input 2
7	Not used

Connector 3 Free female plug
Relay outputs (advanced version only)

Pin	Function
1	Relay 1 common
2	Relay 1 normally open
3	Relay 1 normally closed
4	Relay 2 common
5	Relay 2 normally open
6	Relay 2 normally closed
7	Not used

Connector 4 Free female plug (Wall-mounted version only)
Sensor cable connections (colours are for LTH 54G cable)

Pin	Colour	Function
1	Brown	E
2	Green (coax screen)	G
3	Coax core	C
4	Yellow + blue	Temperature input A
5	Black + white	Temperature input B
6	Green/yellow	Outer screen
7	Not used	

Note: Pins 4 and 5 each have two wires connected.

3.3.1 Power Supply

The unit requires a supply between 15 and 30V (24V nominal) at 200 mA.

Note: The maximum current output load resistance depends on the unit supply voltage: $R_{load} = (V_{supply} - 2) / 0.04$

3.3.2 Current Output Connections

The Basic HCT63 has a single current output of 0-20 or 4-20 mA. The Advanced version has two such outputs designated A and B. The current output ranges are selected via the instrument menu.

For best noise immunity use a screened twisted pair cable, with the screen connected to Earth at one end.

Use a sufficiently large cable to avoid a high resistance in the overall current loop.

3.3.3 Relay Connections

The relay outputs are available only on the Advanced version. The relay contacts are volt-free (electrically isolated) and can handle up to 5A at 30V DC or 250V AC. **They must be connected in series with a 5 Amp fuse.**

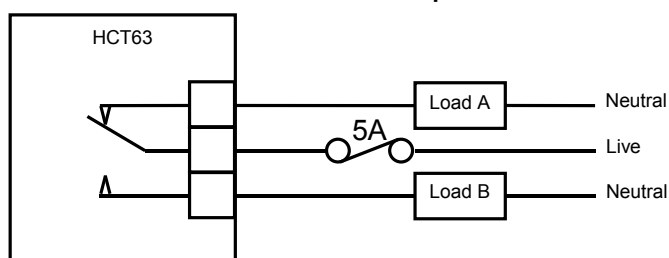

Figure 5 : Relay contact connection

Depending on the load, a contact arc suppressor may be required to prevent excessive electrical noise. To switch more than 5 Amps, use a slave relay.

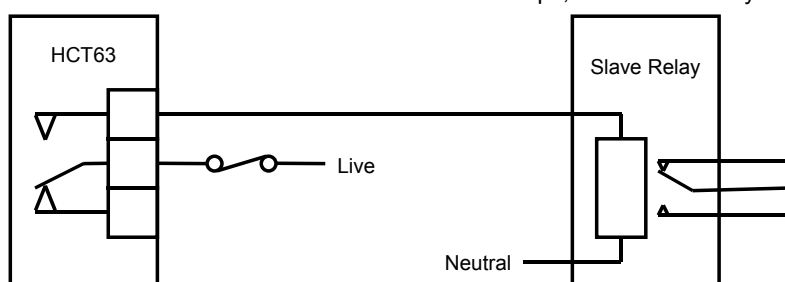

Figure 6 : Slave relay connection

3.3.4 Digital Inputs

The digital inputs are used to change the display ranging of the unit. This also affects both the Set Point range and the Current Output range. When the digital inputs are set for internal ranging, the unit will revert to its internal range settings (see *Section 7 Parameters*). When Autoranging is selected, the Set Points and Current Output will revert to the internally set ranges (see *Sections 8 Set Point Relays and 9 Current Output*). On the following table, 0 is an open contact and 1 is a contact shorted to the common pin 1.

Depending on the cell constant, certain ranges may not be available (see Section 1.2.1 Range & Sensor Compatibility Tables. In which case, the nearest available range will be used. For example, if you select a conductivity range of 0.999 $\mu\text{S}/\text{cm}$ with a cell constant of 1.000, the 99.99 $\mu\text{S}/\text{cm}$ range will be used.

External range control operation			Switch		
Conductivity Range	Resistivity Range	TDS Range	1	2	3
Internal	Internal	Internal	0	0	0
0 to 9.999 $\mu\text{S}/\text{cm}$	0 to 9.999 $\text{k}\Omega\text{-cm}$	0 to 9.999 ppm	0	0	1
0 to 99.99 $\mu\text{S}/\text{cm}$	0 to 99.99 $\text{k}\Omega\text{-cm}$	0 to 99.99 ppm	0	1	0
0 to 999.9 $\mu\text{S}/\text{cm}$	0 to 999.9 $\text{k}\Omega\text{-cm}$	0 to 999.9 ppm	0	1	1
0 to 9.999 mS/cm	0 to 9.999 $\text{M}\Omega\text{-cm}$	0 to 9999 ppm	1	0	0
0 to 99.99 mS/cm	0 to 99.99 $\text{M}\Omega\text{-cm}$	0 to 99.99 ppt	1	0	1
0 to 999.9 mS/cm	Auto range	Auto range	1	1	0
Auto range	Auto range	Auto range	1	1	1

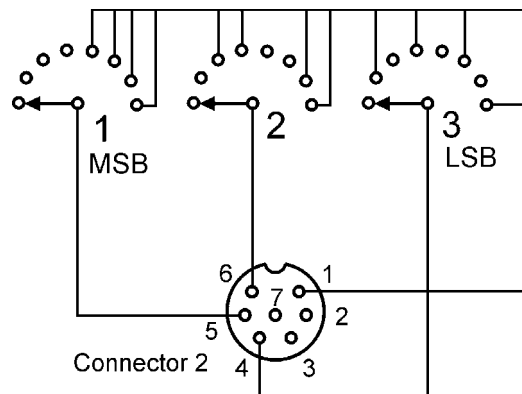
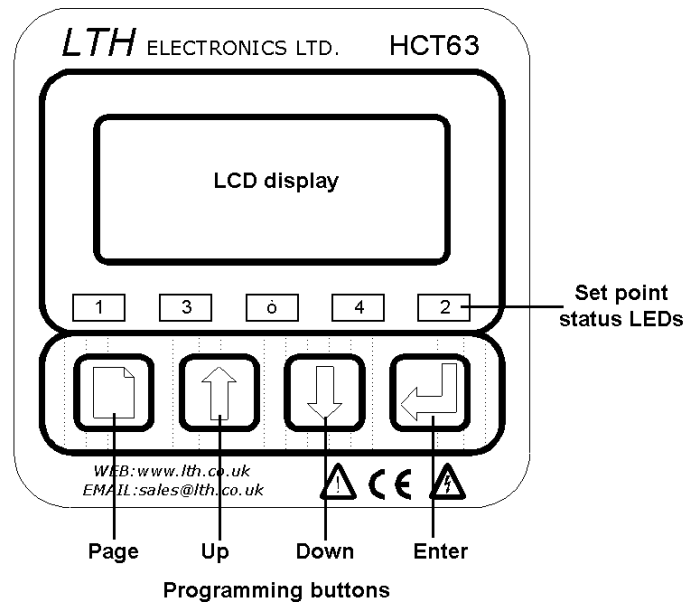

Figure 7 Rotary switch connections for digital range selection

4 User Interface

WARNING! Before proceeding, ensure that the installation instructions have been followed correctly. Failure to do so may result in an electrically hazardous installation, or degrade instrument performance.







When shipped, the HCT63 is configured to the default conductivity set-up (see *Appendix A – Factory Default Setups*). In this state the instrument can perform all of the necessary function for a basic conductivity monitoring instrument.



4.1 The Front Panel



The HCT63 uses a versatile LCD to display all of the settings and readings. The seven segment digits at the top of the display indicate the primary measured value during normal operation. The six character display to the right of these indicates the units of measurement when a value is being displayed. The sixteen characters on the bottom of the display to indicate secondary readings or states, and display scrolling error messages.



Along with the LCD display, the front panel also incorporates five LEDs. The two outer LEDs (labelled 1 and 2) indicate the set point status, i.e. when the LED is illuminated the indicated relay is active. The centre LED indicates when the unit is Off-line. *Note: Not all relay channels may be fitted.*

The four keys - , ,  and  - allow the user to control and configure the unit. The keys are used for changing display options, navigating around the menu system and for changing unit parameter values. To operate a key, press it until the display responds (about half a second). If you hold a key down, the display will cycle through the available options at a rate of about one per second.

4.2 The Menu System

The fold-out sheet at the end of the manual shows the menu system. Each column constitutes a menu. Use the  (Page) key to move from one menu column to the head of the next. When you select the next menu, the display shows the menu title e.g. Parameters. Pressing  with  moves backwards through the menus.

Use the  and  keys to move up and down the menu options in each column. Depending on the current settings, some menu options may not be present. For example, if Set Point 1 is disabled, the screen displaying Set Point 1 will not appear.











When the instrument is switched on, it shows the main display screen. You can use the  and  keys to select various display options, depending on the configuration of the unit. However, on pressing the  (page) key to reach the configuration menus, the first screen encountered is the Access Code screen. To proceed beyond this screen you must enter an access code as detailed in *Section 18 Menu Access*.

Note: When in the menu structure, if none of the buttons are pressed for two minutes, the unit will time out and return to the main display. The Access Code display will be reset to 0000, 30 seconds after returning to the main display.



4.3 Unit Configuration





The unit can be configured by navigating around the menu system and setting up the various unit facilities.

The general principle of setting a parameter is as follows:



1. Use the , , and  keys to navigate to the parameter to be changed.
2. Press the  key to select the parameter for editing. The current parameter value will start to flash, indicating that it can be changed.
3. Use the  and  keys to cycle through the available values of the parameter to the required value.
4. Press the  key to confirm your selection of the required value. The parameter value will stop flashing, indicating that it has been set.
5. Use the , , and  keys to navigate to the next parameter to be changed.

This method can be used for:





- Turning a facility on or off, e.g. **Temperature Compensation** in the **Parameters** menu. The  and  keys toggle the facility on and off.
- Selecting between several options, e.g. **Unit** types in the **Parameters** menu.
- Setting a numeric value such as an access code or trigger level. See *Section 4.4 Number entry*.

For functions such as Resets and Restoring Setups, press the  key to initiate the function, the system will then ask for confirmation. Press  to confirm the function:  or  to cancel.

4.4 Number entry



The ,  and  keys allow you to set up a number between 0000 and 9999 on the main seven-segment display as a parameter value or access code.

To set up a number, proceed as follows:

1. Press  to begin editing a number. The first (left-hand) digit will start to flash.
2. Use the  and  keys to increment or decrement the flashing digit.
3. When the flashing digit is correct, press  to confirm the setting. The next digit will start to flash.
4. Repeat steps 2 and 3 to set the remaining three digits.
5. After pressing  to confirm the last digit, none of the digits will be flashing and the number is then ready for use.

If the number is an access code, the Padlock symbol on the display will change to a Key symbol if the new code you have entered is correct. If the number is a parameter value, the parameter has now been set to that value.



4.5 Error Messages

If the internal diagnostics have detected an error condition, the appropriate error message will flash on the bottom row of the display. A reference to these error messages can be found in *Appendix H – Error Messages*. Pressing the  key when an error message is flashing will scroll a more detailed description of the error along the bottom line. Pressing  again will return the unit to the flashing display. The error messages can be disabled within the **Configuration** menu (see *Section 12.2 Error Messages*). If the error messages are disabled, the display will flash a bell symbol on the far right of the bottom row when an error is detected. It is possible to configure a set point relay to provide external signalling of error conditions (see *Section 8.7 Alarms*).

5 Main Display

There are two modes of display operation – digital and bargraph. The mode can only be changed via the Configuration menu, requiring the Level 2 access code.

In bargraph mode, the display shows an analogue representation of Output A or B, or both, alternating. The output identity and units are shown in the upper display. If bargraph mode is selected, digital displays are not available, and vice versa.

In digital mode, the display shows the sensor reading, in the units assigned via **Parameters/Units**, on the top row and a secondary reading on the bottom row. The user can select the desired secondary reading parameter by means of the  and  keys (without the need to enter an access code).

The secondary parameters vary according to the instrument configuration, and are as follows:

Sec.display	Comment
Temp. input	Units C or F, as selected via Parameters/Temperature Units
Output A	This shows the output current from Channel A in mA.
Output B	This shows the output current from Channel B in mA.
SP1	This appears when Set Point 1 is enabled and trigger is set to Low or High. It shows set point value in the assigned units.
SP1H	This appears when Set Point 1 is enabled and trigger is set to Band, Latch Lo or Latch Hi. It shows set point upper value in the assigned units.
SP1L	This appears when Set Point 1 is enabled and trigger is set to Band, Latch Lo or Latch Hi. It shows set point lower value in the assigned units.
SP2	This appears when Set Point 2 is enabled and trigger is set to Low or High. It shows set point value in the assigned units.
SP2H	This appears when Set Point 2 is enabled and trigger is set to Band, Latch Lo or Latch Hi. It shows set point upper value in the assigned units.
SP2L	This appears when Set Point 2 is enabled and trigger is set to Band, Latch Lo or Latch Hi. It shows set point lower value in the assigned units.

The default secondary parameter can be set by selecting the parameter and pressing the  key (provided that no error messages are present). This is the parameter that is displayed on the bottom line when the unit is switched on, or as a result of a timeout back to the normal display mode.

If the unit has detected an error, an error message will flash alternately with the secondary parameter or bargraph. See *Appendix H – Error Messages*.

6 Menu Access

The instrument parameters are protected against unauthorised or accidental tampering by access codes.

There are three levels of access – Basic, Level 1 and Level 2. For Basic access, no access code is required but access is restricted to the main display modes. A user with Level 1 access can change some parameters and Set Point trigger levels. A user with Level 2 access has full access to all user-selectable parameters. The pull-out chart at the rear of this manual shows the access permitted the three levels.

When the unit is switched on, it shows the main display screen. To reach the menu system from there, press the  key to reach the Access Code screen and then enter the Level 1 or Level 2 access code. A character on the right of the display indicates whether or not access is permitted. The character will be a key for permitted access and a padlock for denied access.

As supplied, the unit has the following default access codes:

0001 **Restricted access at Level 1.**

0002 **Full access at Level 2.**







On first use, it is recommended that the user change the access codes to restrict unauthorised access. See *Section 6.1 Changing the Access Code*.

Entering the access code for a level, e.g. for Level 2, gives access to that level. The procedure for entering the access code is detailed in *Section 4.4 Number entry*. On entering a valid code, the padlock character on the display changes to a key.

6.1 Changing the Access Code

On first use, it is recommended that the user change the access codes to restrict unauthorised access.

You need Level 2 access in order to change the Level 2 access code. You can change the Level 1 access code if you have either Level 1 or Level 2 access.

1. From the Main Display screen, press  once to reach the Access Code screen.
2. Use the  and  keys to reach the Set Level 1 (or 2) Code screen.
3. Use the ,  and  keys to edit and store the new access code, as described in *Section 4.4 Number entry*.

7 Parameters

The **Parameters** menu contains the basic configurations for the sensor inputs. The various parameters can be changed using the method described in *Section 4.3 Unit Configuration*.

The Parameters menu structure is as follows:

```

Parameters
  Units
  |   Ohms.cm – Resistivity
  |   Siemens/cm – Conductivity
  |   TDS – Total Dissolved Solids
  Cell Constant (0.00 – 1.00)
  Range (or External Range)
  |   Auto
  |   99.99 µS
  |   999.9 µS
  |   9.999 mS
  |   99.99 mS
  T Units
  |   °C
  |   °F
  TC (Temperature Compensation)
  |   Out
  |   In
  |       TC Base
  |       |   +20°C
  |       |   +25°C
  |       TC Slope (0.0-3.9)
  |       TC Mode
  |       |   Auto
  |       |   Manual
  |       |   0-100 °C
  Sim current OutA
  Sim current OutB (advanced model only)
  
```

7.1 Units

This menu does not appear when either of the set points is set to USP26.

The HCT63 can be setup to display conductivity in Siemens/cm, resistivity in $M\Omega.cm$ or TDS (Total Dissolved Solids) in ppm. This is achieved by simply setting the appropriate units. The rest of the menu structure for the instrument responds by enabling and disabling the appropriate menu items. When Siemens are selected, the instrument displays the basic input conductivity. All appropriate set point levels etc have their units changed automatically.

Parameters

When TDS is selected the HCT63 will display the conductivity as ppm using a factor which can be adjusted between 0.50 and 0.90. All of the set point units etc. will then be changed to ppm.

7.2 Cell Constant

The HCT63 is designed to use LTH conventional conductivity sensors. This menu item enables the user to edit and store the cell constant which should be marked on the sensor. Cell constants $K=0.1$ and 0.01 can be further adjusted under the Calibration menu (see *Section 7.2 Cell Constant*).

7.3 Range

The instrument range can only be set from this menu when no specific range has been selected via the digital inputs (see *Section 3.3.4 Digital Inputs*). Where the range has been set by external switches, the display indicates the externally-selected range when this menu option is selected.

7.4 Temperature Input

The HCT63 has a very accurate PRT temperature measurement facility. With this the user can apply automatic temperature compensation to the sensor measurement.

The T. Units option allows you to select a temperature display in either °C or °F. All temperature related displays will reflect the units selected in this menu.

Note: Under normal conditions the system will convert all temperature related variables when the units are changed. However it may be wise to check that changing the units has not altered the Temperature Compensation settings.

The temperature compensation is enabled by setting the **Temp Comp** menu item to **In**. The operator can then select between two modes of compensation by selecting the **TC Mode**. menu item. If a temperature sensor is not connected to the instrument then it should be **Disabled** in the **Configuration** Menu see *Section 12.2 Temperature Input Sensor*. In this mode the instrument can be set with the TC **Out** which will provide a non compensated measurement, or with the TC set to **In** and the **Manual** temperature set to the average solution temperature. When the manual mode of operation is selected, the user can enter the fixed process temperature under the **Fixed Temp** menu option.

Note: When the automatic mode is selected, the Fixed Temp menu option will not be present.







Note: When a fault is detected in the Temperature sensor, the unit will default to the Fixed Temp setting for compensation purposes, but will display an error condition

The Slope and Base for the Temperature Compensation can be modified by selecting the appropriate menu items.

7.5 Simulated Inputs

The **Simulate current outputs** options are only available when the display range is set to a fixed range (not to Autoranging) and the chosen output source is not disabled.

These options provide simulated inputs to allow testing of the set point and current output operations.

Select the required menu option, for Current A or Current B output, and press the  key to display the simulation menu. Press the  and  keys to cycle the displayed value between its minimum and maximum levels in steps of approximately 1% of its input range. Alternatively press  with  or  to change the value in 10% steps. The relays and current output will respond as if the displayed value were an actual input, thus allowing you to debug the set point and current output configurations.

Note: Only one input can be simulated at a time.

8 Set Point Relays

Two Set Point relays, designated SP1 and SP2, are fitted on the Advanced version of the HCT63. No relays are fitted on the basic version. Indicators on the front panel show when a relay has operated.

A relay can be set to operate when a sensor or temperature set point is exceeded or when an alarm occurs. The menu structures for set points 1 and 2 are identical, and provide a high level of flexibility in the configuration of the relay outputs, as follows:

SPn Source (SP1 or SP2)

```

Disabled - no further SPn options are available
Sensor IP (or Temp IP)
|
|   Set point range (Sensor IP only, if Autoranging selected)
|   Trig: Hi (or Lo)
|   |
|   |   Set point n value
|   |   SPn: Mode
|   |   |
|   |   |   On/Off
|   |   |   PP – Pulse Proportional
|   |   |   TP – Time Proportional
|   |   SPn: Dose Alarm No
|   |   |
|   |   |   Yes - SPn Alarm time
|   |   SPn: Delay (On/Off mode only)
|   |   SPn: Hysteresis (On/Off mode only)
|   |   SPn: Cycle Time (TP mode only)
|   |   SPn: Proportion (PP and TP modes only)
|   Trig: Lo – see Trig: Hi
|   Trig: Band
|   |
|   |   High set point
|   |   Low set point
|   |   SPn: Dose Alarm No
|   |   |
|   |   |   Yes - SPn Alarm time
|   |   SPn Delay
|   |   SPn Hysteresis
|   Trig: Latch Hi (or Lo)
|   |
|   |   High set point
|   |   Low set point
|   |   SPn Dose Alarm No
|   |   |
|   |   |   Yes - SPn Alarm time
|   Trig: Latch Lo – see Trig: Latch Hi
|   Trig: USP26
|   |
|   |   SP2 USP Pre-Trig (if SP1 set to USP26)
Temp IP - see Sensor IP
Alarm
|
|   Alm: Disabled
|   Alm: Sensor Err
|   Alm: Dose Alarm
|   Alm: Calibration
|   Alm: Off-line
|   Alm: Any Error
    
```

8.1 Set Point Source

Each set point relay can be disabled or triggered from a sensor input (the default), a temperature input or from an alarm.

8.2 Set Point Range

If the main sensor display has been set to Autoranging then the Sensor Set Point is scaled according to the setting of the **Set Point Range** menu item. The range can be set from 999.9 μ S/cm to 999.9 mS/cm.

8.3 Set Point Trigger

The set points can be configured to trigger from the sensor or temperature source in six ways:

- | | |
|----------------|---|
| Trig: Hi | The relay will be activated when the source input becomes greater than the set point. Delay and hysteresis can be applied. |
| Trig: Lo | The relay will be activated when the source input becomes less than the set point. Delay and hysteresis can be applied. |
| Trig: Band | The relay will become activated when it is either greater than the Band High set point, or lower than the Band Low set point. Delay and hysteresis can be applied. |
| Trig: Latch Lo | the relay energises when the source input falls below the Band Low level and remain energised until it rises above the Band High level. It then remains de-energised until the sensor input falls below the Band Low level again. |
| Trig: Latch Hi | the relay energises when the source input rises above the Band High level and remain energised until it falls below the Band Low level. It then remains de-energised until the sensor input rises above the Band High level again. |
| USP26 | See <i>Section 8.6 USP26 OPERATION</i> |

8.4 Set Point Mode

The relays can operate in one of three modes.

8.4.1 On/Off Mode

The On/Off mode is the default mode of operation for the relays. The relay energises when the set point is activated and is de-energised when the set point is de-activated.

Delay: In order to prevent short duration changes at the input affecting the relay operation a delay can be set before the relay energises. If the input is still the same after the delay, then the relay will be energised.

Hysteresis: A facility to apply hysteresis to the set point level allows the user to avoid relay chatter when the sensor input level approaches the set point level. Chatter is caused when the sensor input is sufficiently close to the set point value and noise on the signal repeatedly crosses the set point level, thus causing the relay to switch on and off rapidly.

The hysteresis level should therefore be set to be a little larger than the input noise level.

In addition to the On/Off mode the HCT63 also provides two forms of pseudo proportional control, which can be used to control the levels to a defined value when used in conjunction with a pump or valve. When the reading deviates from the programmed set point level the relay pulses at a rate proportional to that deviation.

8.4.2 Time Proportional Mode

It is possible to control any on/off device such as a solenoid valve or dosing pump using the time proportional mode.

The proportional band is displayed as a percentage of the full range value. For example, a proportional band of 20% on the 99.99 $\mu\text{S}/\text{cm}$ range would give a band of 20.0 $\mu\text{S}/\text{cm}$. If the set point trigger was selected as LOW and the set point value was 50.0 $\mu\text{S}/\text{cm}$, the band would cover 30.0 to 50.0 $\mu\text{S}/\text{cm}$. When the reading falls below 30.0 $\mu\text{S}/\text{cm}$ the relay would be energised. As the input rises and approaches the set point the output relay starts to cycle on and off with the on time reducing and the off time increasing, respectively. The cycle time can be set by the user and is the sum of the on and off times.

8.4.3 Pulse Proportional Mode

The Pulse Proportional (or PP) mode is intended to drive solenoid type dosing pumps which have the facility to accept an external pulse input. The proportional band operates in the same way as the Time Proportional mode. The output relay now operates by producing a series of pulses of fixed duration. The pulse rate increases as the measurement moves further from the set point, until it reaches the maximum frequency at the limit of the proportional band. (I.e. 30.00 $\mu\text{S}/\text{cm}$ in the previous example).

8.5 Dose Alarm Timers

The dose alarm timer can be used to prevent overdosing under many different fault conditions, such as sensor failure or wiring faults. When the timer is enabled the user can set the **Alarm Time**. If the associated relay remains energised for longer than the **Alarm Time** the alarm will activate, de-energising the relay to prevent overdosing and flash the set point LED on the front panel. The display will also flash a warning message when the alarm is activated.

Note: During pulse or time proportional operation, the cumulative on-time that the set point is active will be taken.

To cancel the warning, and reactivate the set point, press the  key on the front panel.

Note: If more than one Alarm is active, set point 1 takes priority over set point 2 and they are cancelled in that order by additional presses of the  key.

8.6 USP26 Operation

Set points 1 and 2 can be set to activate in accordance with the limits specified in USP26 (United States Pharmacopia specification No. 24). To do this simply select USP26 in the trigger menu item. The rest of the menus for that set point will then be disabled. In addition, set point 2 has been given the facility to add a **Pre-Trigger**. This pre-trigger can be set anywhere from 0 to 9.999 $\mu\text{S}/\text{cm}$, and will cause set point 2 to activate by the pre-trigger amount before the USP26 level. This provides the user with a warning when the conductivity is approaching the USP26 defined limits. It should be noted that when either set point is set to USP26 operation the **TC** will be switched **OUT**.

To make it easier to configure the unit for USP26 operation, a **Default USP26** menu has been added to the **Save/Restore** menu (see *Section 11 Save/Restore* and *Appendix A – Factory Default Setups*). This will automatically configure the set points and the current outputs to a broadly representative set-up necessary for USP26 operation, though some fine tuning may be required to meet your exact needs.

Set Point Relays

8.7 Alarms

The two set point relays can be configured as an alarm output triggered by one of the following events:

- Sensor error
- Dose alarm
- Calibration – when a calibration is in progress.
- Off-line – unit has been taken off line, e.g. for servicing.
- Any error – when any system error is detected.

To set an alarm output, choose the SP1 or SP2 menu, select **Alarm** from the menu options and then select the required trigger.

9 Current Output

The current output menu structure contains all of the necessary set-up functions to configure the current output source(s). If one current output is fitted, then the menu will be as follows. If two current outputs are fitted they are referred to as A and B respectively.

The menu structure is as follows:

```

O/P Source (A or B)
  Disabled
  Sensor IP
  |       Select Output (0/4-20 mA)
  |       Output A/B Range (if Parameters/Range is set to Auto)
  |       |       99.99 µS
  |       |       999.9 µS
  |       |       9.999 mS
  |       |       99.99 mS
  |       Output A/B Zero
  |       Output A/B Span
  Temp IP
  |       Select Output (0/4-20 mA)
  |       Output Zero
  |       Output Span

```

On Error = (No, 22 mA or 0 mA)

The maximum load resistance that the current output can drive depends on the power supplied to the unit and is: $R_{load} \text{ (Ohms)} = (V_{supply} - 2) / 0.04$.

9.1 Input

The unit can use the sensor input or the temperature input as the sources for the current outputs. Alternatively, the source can be switched off by selecting **Disabled** for that source.

9.2 Select Output

The output range for the current output can be set to one of two ranges, either 0 – 20 mA or 4-20 mA. This selection sets the limits of the zero and span output levels. The output will continue to provide an extrapolated output above (>20 mA) and below (<4 mA) these points but will flag an error message on the main display. The maximum current limit is approximately 22 mA, the minimum limit is 0 mA (i.e. the unit cannot source a negative current)

9.3 Output Range, Zero & Span

The zero and span levels define the limits of the source input. This provides a totally flexible method of configuring the current output. The zero can be set anywhere within the input source range and the span up to 5% of the selected range, providing total control of the output range and offset. An inverse relationship can easily be achieved by simply setting the zero level to be higher than the span level.

Since the Span can only be specified as a four-digit number between 0000 and 9999, the Output Range option allows you to specify the value represented by the Span you enter. Hence, if you specify an Output Range of 99.99 μS then a Span entry of 1500 represents a span of 15.00 μS . The Output range only has to be specified if the display range, set via **Parameters/Range**, has been set to **Auto**. If **Parameters/Range** has been set to a specific range, the Current Output will operate on that range.

9.4 Proportional Control

Many devices such as motor speed controllers, valve actuators, or stroke positioners will accept an analogue 4-20 mA control signal.

It is possible to use the measurement signal from the instrument as a control signal. By setting the point at which the output is 4 mA as the set point (e.g. 50.00 $\mu\text{S}/\text{cm}$) and the point at which the output is 20 mA as the proportional band (e.g. 20.00 $\mu\text{S}/\text{cm}$) a simple form of proportional control is achieved. If this signal was used to drive a valve actuator, the valve would be fully open at 20.00 $\mu\text{S}/\text{cm}$, half open at 35.00 $\mu\text{S}/\text{cm}$ and closed at 50.00 $\mu\text{S}/\text{cm}$.

9.5 Error Condition

The current outputs can be programmed to output 22 mA or 0 mA when an error is detected on the source (i.e. Sensor Fault, Temperature Over or Under Range). This can provide remote warning of error conditions or to ensure fail safe operation. The default state is disabled (parameter is set to **No**).

10 Calibration

The HCT63 provides the facility within the **Calibration** menu to adjust the sensor inputs and current output levels to tailor the unit to the system in which it is operating.

The menu structure is as follows:

- Mode:
 - On-line
 - Off-line
- Sensor Reading Calibration
 - Are you sure?
 - Sensor reading displayed/adjusted
 - Slope displayed
- Temperature Calibration (if TC mode set to Auto)
 - Are you sure?
 - Temperature reading displayed/adjusted
- Cell Constant
 - Are you sure?
 - Cell Constant displayed/adjusted
- Current Output A/B Calibration
 - Are you sure?
 - Adjust 0 mA
 - Adjust 4 mA
 - Adjust 20 mA
- Reset User Calibration
 - Are you sure?
 - Resetting

10.1 On-Line/Off-Line Operation





Selecting the **Mode** menu will allow the user to place the unit in the **Off-line** state. If the state is set to **Off-line** the relays will be de-energised and the current output level frozen for the duration of the **Off-Line** state. When **On-Line** is selected the relays and current output will operate normally. The middle LED on the front panel display will indicate when the unit is **Off-Line**.

10.2 Sensor Calibration

Use this option to calibrate the sensor against a known solution. Proceed as follows:







1. Ensure that the sensor is immersed in a solution of known conductivity or resistivity.
2. From the Sensor Reading page, press the  key. The screen will display 'Are you sure?'.

Calibration

3. Press  to confirm (or any other key to abandon calibration). On pressing , the display will show the sensor reading.
4. Use the  and  keys to set the reading to the known correct value.
5. Press  to confirm the correct reading. The display will show the slope calculated by the instrument (where 100% is the default).

10.3 Temperature Calibration

Use this option to calibrate the temperature sensor against a solution at a known temperature. Proceed as follows:

1. Ensure that the sensor is immersed in a solution of known temperature.
2. From the **Temperature Calibration** page, press the  key. The screen will display 'Are you sure?'.
3. Press  to confirm (or any other key to abandon calibration). On pressing , the display will show the temperature reading.
4. Use the  and  keys to set the reading to the known correct temperature.
5. Press  to confirm the correct reading. The display will show the slope calculated by the instrument (where 100% is the default).



10.4 Cell Constant Adjustment

To ensure specified accuracy in the lower constant cells (0.1, 0.01) it is necessary to enter the exact cell constant (as printed on the cell / label). To initiate the cell constant adjustment, select the **Cell Constant** menu item in the **Calibration** menu and press the  key. It is possible to adjust the cell constant within a range of $\pm 50\%$ (i.e. 0.1500 to 0.0500 for a 0.1 constant cell).

10.5 Current Output Calibration

The user is provided with an opportunity to adjust the current output, to calibrate any equipment that may be being used to monitor the current output signal. To adjust the current output select the **Current Output** menu item in the **Calibration** menu. Please keep in mind that the current output cannot go below 0mA. The maximum offset is $\pm 2\text{mA}$. If two current outputs are fitted they are referred to as A and B respectively.





10.6 Resetting the User Calibration

This option resets all of the user calibrations to their default. From the **Reset User Cal** page, press the  key. The message 'Are you sure?' will appear. Press  to confirm and continue with the reset, or any other key to abandon the reset.

11 Save/Restore

This facility allows you to save and recover two instrument set-ups. You can also recover default settings for Conductivity, Resistivity and USP26 set-ups. The menu structure is as follows:

Save/Restore
Save as Setup A
Save as Setup B
Restore Setup A
Restore Setup B
Default Cond-ity
Default Res-vity
Default USP26

To use these functions select the **Save/Restore** menu item and use the  and  keys to select the required function. Pressing the  key will prompt the unit to ask for confirmation. Pressing the  key again will initiate the function. The unit will then perform the function and then return to the main menu.

This facility is very useful for testing or fault finding. The set-up can be stored prior to testing and restored once testing is complete. The default set-ups are provided to give a basic instrument set-up for each configuration.

Note: There is no protection for the set-up stores other than the systems request for confirmation, so be very careful not to overwrite already saved set-ups.



12 Configuration

Options on the Configuration menu allow you to set up some basic operating parameters. The menu structure is as follows:



```
Configuration
|
| Language (some units only)
|   English
|   Francais
|   Espanol
|   Italiano
|
| Temperature Input sensor (T input)
|   PT1000
|   Disabled
|
| Errors
|   Enabled
|   Disabled
|
| IP Filter
|   Out
|   10 Secs
|   20 Secs
|   40 Secs
|   1 Min
|   3 Min
|   5 mins
|
| Bar Graph
|   Off
|   A
|   B
|   A & B alternating
|
| Software version
```

12.1 Language

This option is not available on some (English-only) units.

Use the  and  keys to select the required language and the  key to confirm your selection.

12.2 Temperature Input Sensor

Use the  and  keys to select or disable the temperature sensor and the  key to confirm your selection.

12.3 Error Messages

Use this option to display or hide any error messages that may occur. Error messages flash alternately with the secondary parameters on the display.

12.4 Input Filtering (Averaging)

When very noisy environments are encountered, this function will allow the user to filter the sensor readings by taking a running average over the time period selected (from 10 seconds to 5 minutes).

12.5 Bargraph

The display can include a bargraph that shows the state of the current outputs. Use the **Bargraph** configuration option to turn the bargraph off or to display output current A or B, or both, alternating.

The bargraph display is an alternative to digital displays. If the unit is configured to show a bargraph display, only the bargraph will be displayed - the user will not be able to select digital displays. Digital displays can only be restored by changing the **Bargraph** option on the **Configuration** menu.

12.6 Software Version

This option displays the version number of the software embedded in the unit.

13 Fault Finding

NOTE : THERE ARE NO USER SERVICEABLE PARTS INSIDE THE UNIT

The HCT63 has been designed to include a wide range of self diagnostic tests, some of which are performed at switch on, and some on a continuous basis. This guide aims to provide a route to diagnosing and correcting any faults that may occur during normal operation. The table shown in Appendix H – Error Messages gives a list of the error messages that the HCT63 generates, along with their probable causes. If the fault has not been cleared after these checks have been made, contact LTH. Please have as much of the following information available as possible, in any communication with LTH, to enable quick diagnosis and correction of the problem.

- Serial number of the instrument,
- The approximate date of purchase.
- Details of the program settings and application
- Electrical environment and supply details
- Circumstances under which the fault occurred.
- The nature of the fault or faults
- Any error messages that are displayed
- The sensor type, cable length and type
- Current output configuration
- Relay connection configuration
- Software version.

It is often worthwhile to check the measurement by an independent method, for example using a handheld meter. (See also *Section 2.2 Noise suppression.*)

Note: Low conductivity = high resistivity

The Instrument Appears Dead

Check that power is available to the unit. Using a voltmeter, set to AC or DC (as appropriate), check the power supply voltage at the connector. The unit can accept from 15 to 30V AC or DC. Check that the power cable is securely and correctly attached – wired as detailed in *Section 3.3 Connections*. There are no user serviceable fuses fitted within this unit.

The Access Code Does Not Work

It is probable that the access code has either been changed or the operator does not recall the code correctly. Contact LTH or your local distributor should this problem arise.

The Sensor Reading Is Constantly Over-range or Under-range

1. Ensure that the sensor and temperature inputs are correctly connected (wall-mounted version only, see *Section 3.3 Connections*) and that the sensor is not faulty or damaged.
2. Check that the correct range and Cell Constant have been selected within the Parameters menu if in doubt set to **Auto** Range (see *Section 7.1 Units*).
3. Check the temperature compensation state (see *Section 7.4 Temperature Input*). If the compensation is set to Manual check that the fixed temperature is at the correct level. If the compensation is Automatic check that the temperature reading on the main display is correct (see *Section 5 Main Display*).
4. Check the sensor using a hand held meter.
5. Check that the sensor is seeing a representative sample, trapped air will give a low reading.
6. Ensure the input is correctly connected and the sensor is not faulty or damaged.
7. Check the sensor and its cable for possible short circuits. Consider the fact that the conductivity may be higher than the range of the instrument.
8. Check the Pt1000 RTD temperature sensor connections.
9. Check that any in-line junction boxes and extension cables have been fitted and wired up correctly.

The display reads zero

1. Check for open circuit sensor (conductivity or TDS modes)
2. Check for short circuit sensor (resistivity mode)
3. Check for damage to the sensor connecting cable (wall-mounted version only).
4. Check that all input connections are secure.
5. Check the sensor is wired up correctly (wall-mounted version only).
6. Check that the sensor bore is not blocked or completely filled with air.
7. Check the sensor is immersed in the solution, i.e. the T-piece or pipe is full and not an 'air-trap'.

Instrument display appears to malfunction

1. Switch the instrument power off and on again.
2. Check that the display back-light is on, indicating power is reaching the unit.
3. See that it displays meaningful text (software issue number etc.) in it's start-up sequence, indicating processing activity.

Fault Finding

The Sensor Reading Is Incorrect

1. Low reading due to incomplete immersion or contamination of the electrodes.
2. There may be some trapped matter within the sensor bore.
3. High conductivity readings caused by a short circuit or leakage of liquid contamination into the sensor moulding.
4. The sensor should be checked, when dry, with an ohmmeter. Disconnect it at the instrument and check the resistance between the E and C terminals. It should be greater than 50 M Ω between E & C. Check the leakage from E & C in turn to the terminated screens (inner and outer). Again, 50 M Ω should be the minimum isolation resistance between them all.
5. Low conductivity can be caused by accumulation of trapped air or gas coming out of solution. Check that no air traps exist in the sensor installation.
6. High conductivity readings caused by leakage of solution into the sensor. This usually indicates that the sensor material has been fractured and the sensor must be replaced.
7. First check that the temperature resistance is correct, otherwise the temperature compensation circuit will cause false or erratic readings. Temporarily switching out the temperature compensation can help to show if this is the cause of the problem.
8. If another conductivity sensor is available, this can be used to determine whether the fault lies with the instrument or the sensor (wall-mounted version only).
9. Check that the sensor cable is not damaged or broken and that the outer screen does not make contact with any other terminals or metal work (wall-mounted version only).
10. Check that the inner screen (G) does not contact any other terminals or metalwork at the sensor end. It should not be grounded (wall-mounted version only).
11. Check that the sensor cable is sufficiently distant from power cables or electrical noise sources (wall-mounted version only).
12. Check that the correct sensor type has been installed.
13. Check that the correct range has been selected.
14. Check that the correct sensor calibration values have been used.
15. Check that the calibration procedure has been followed precisely.
16. Check that the temperature compensation has been set up as required.
17. Check that the sensor cable does not exceed the maximum specified length (10m) (wall-mounted version only).

The Temperature Reading Is Incorrect

1. Check that the temperature sensor is wired correctly. (wall-mounted version only) (see *Section 3.3 Connections*).
2. Check that the temperature sensor is correctly selected in the Configuration menu (see *Section 12.2 Temperature Input Sensor*).
3. Where practical check the temperature sensor resistance against the table in *Appendix F – Temperature Data*.

Current Output is Incorrect or Noisy

1. Check that the maximum load has not been exceeded. See *Section 3.3.1 Power Supply*.
2. Check that the connectors have been wired correctly (see *Section 3.3 Connections*).
3. Check that the cable screen is attached to earth at one end, and that the cable does not pass too close to a power cable.
4. Check that the current output has been configured properly (see *Section 9 Current Output*).

Relays Appear to Malfunction

1. Check that the unit is On-Line (see *Section 10.1 On-Line/Off-Line Operation*)
2. Check that the set point configuration is correct (see *Section 8 Set Point Relays*)
3. If the relays are vibrating or chattering as they pass the set point, check the hysteresis setting (see *Section 8.4.1 On/Off Mode*) and increase if necessary.
4. Ensure that the relays are connected properly (see *Section 3.3.3 Relay Connections*) and that the voltage/current levels are not exceeding the specification (see *Section 1.2 Unit Specification*).
5. Check that the instrument input cables are not picking up excessive noise, (see *Section 2.1 Wiring Installation*).

A Bell Symbol is Flashing on the Display

The system has detected an error but the error messages have been disabled in the **Configuration** menu (see *Section 12 Configuration*). Enable the error messages, correct the error and then disable the error messages only if absolutely necessary.

14 Guarantee and Service

Products manufactured by LTH Electronics Ltd are guaranteed against faulty workmanship and materials for a period of three years from the date of despatch, except for finished goods not of LTH manufacture, which are subject to a separate agreement.

All sensors made by LTH Electronics Ltd are thoroughly tested to their published specification before despatch. As LTH have no control over the conditions in which their sensors are used, no further guarantee is given, although any complaints concerning their operation will be carefully investigated.

Goods for attention under guarantee (unless otherwise agreed) must be returned to the factory carriage paid and, if accepted for free repair, will be returned to the customer's address free of charge. Arrangements can also be made for repair on site, in which case a charge may be made for the engineer's time and expenses.

If any services other than those covered by the guarantee are required, please contact LTH direct.

Note: Overseas users should contact their LTH nominated representative. Special arrangements will be made in individual cases for goods returned from overseas.

Guarantee and Service

15 Appendix A – Factory Default Setups

	Conductivity	Resistivity	USP26
Parameters			
Units	Siemens	MΩ.cm	Siemens
Cell Constant	1.00	0.01	0.01
Range	Auto	Auto	Auto
Temperature Units	°C	°C	°C
TC	In	In	Out
TC Base	25°C	25°C	Not applicable
TC Slope	2%/°C	2%/°C	Not applicable
TC Mode	Automatic	Automatic	Not applicable
Manual Temperature Input	+25.0°C	+25.0°C	Not applicable
Set Points			
SP1 Source	Sensor	Sensor	Not applicable
SP1 Range	99.99 μS/cm	99.99 MΩ	Not applicable
SP1 Trigger	Low	Low	USP26
SP1 Level (Band High)	75.00 μS/cm	20.00 MΩ	Not applicable
SP1 Band Low	25.00 μS/cm	10.00 MΩ	Not applicable
SP1 Mode	On/Off	On/Off	Not applicable
SP1 Dose Alarm	No	No	Not applicable
SP1 Alarm Time (mm:ss)	05:00	05:00	Not applicable
SP1 Delay (mm:ss)	00:00	00:00	Not applicable
SP1 Hysteresis (% of SP Level)	1.0%	1.0%	Not applicable
SP1 Cycle Time (mm:ss)	00:30	00:30	Not applicable
SP1 Proportional Band (% of range)	20.0%	20.0%	Not applicable

Appendix A – Factory Default Setups

SP2 Source	Sensor	Sensor	Not applicable
SP2 Range	99.99 $\mu\text{S/cm}$	99.99 $\text{M}\Omega$	Not applicable
SP2 Trigger	High	High	USP26
SP2 Level (Band High)	75.00 $\mu\text{S/cm}$	20.00 $\text{M}\Omega$	0.200 $\mu\text{S/cm}$ *
SP2 Band Low	25.00 $\mu\text{S/cm}$	10.00 $\text{M}\Omega$	Not applicable
SP2 Mode	On/Off	On/Off	Not applicable
SP2 Dose Alarm	No	No	Not applicable
SP2 Alarm Time (mm:ss)	05:00	05:00	Not applicable
SP2 Hysteresis (% of SP Level)	1.0%	1.0%	Not applicable
SP2 Cycle Time (mm:ss)	00:30	00:30	Not applicable
SP2 Proportional Band (% of range)	20.0%	20.0%	Not applicable

* USP26 Pre-trigger, see *Section 8.6 USP26 Operation*.

Appendix A – Factory Default Setups

Current Output(s)			
Input A	Sensor	Sensor	Sensor
Output A	4-20 mA	4-20 mA	4-20 mA
Output A Range	999.9 mS/cm	99.99 MΩ	9.999 μS/cm
Output A Zero	0.0 mS/cm	0.0 MΩ	0.0 μS/cm
Output A Span	100.0 mS/cm	20.00 MΩ	9.999 μS/cm
Input B	Temperature	Temperature	Temperature
Output B	4-20 mA	4-20 mA	4-20 mA
Output B Zero	0.0 °C	0.0 °C	0.0 °C
Output B Span	100 °C	100 °C	100 °C
On error	22 mA	22 mA	22 mA
Calibration			
Mode	On-Line	On-Line	On-Line
Calibration Access	No	No	No
Configuration			
Language	English	English	English
T input	Pt1000	Pt1000	Pt1000
Errors	Enabled	Enabled	Enabled
IP Filter	Out	Out	Out
Bargraph	Off	Off	Off

16 Appendix B – Customer Setup

Use this appendix to record unit settings.

Instrument Serial No

Sensor Serial/Type No

Parameters	Settings
Level 1 Code	
Level 2 Code	
Units	
Cell Constant	
Range	
TDS Factor	
Temperature Units	
TC	
TC Slope	
TC Mode	
Manual Temperature Input	
Set Points	
SP1 Source	
SP1 Range	
SP1 Trigger	
SP1 Level (Band High)	
SP1 Band Low	
SP1 Mode	
SP1 Dose Alarm	
SP1 Alarm Time (mm:ss)	
SP1 Delay (mm:ss)	
SP1 Hysteresis (% of SP Level)	
SP1 Cycle Time (mm:ss)	
SP1 Proportional Band (% of range)	

Appendix B – Customer Setup

SP2 Source	
SP2 Range	
SP2 Trigger	
SP2 Level (Band High)	
SP2 Band Low	
SP2 Mode	
SP2 Dose Alarm	
SP2 Alarm Time (mm:ss)	
SP2 Hysteresis (% of SP Level)	
SP2 Cycle Time (mm:ss)	
SP2 Proportional Band (% of range)	
Current Output(s)	
Input A	
Output A	
Output A Range	
Output A Zero	
Output A Span	
Input B	
Output B	
Output B Range	
Output B Zero	
Output B Span	
Configuration	
Language	
T input	
Errors	
IP Filter	
Bargraph	

17 Appendix C - Calibration

17.1 Best Practice for Fine Tuning the HCT63

The HCT63 provides a facility for the operator to fine tune the calibration of the conductivity or resistivity measurement, the temperature measurement and the current output. The amount of adjustment is quite small because the factory calibration is accurate and with modern electronics, drift is very low. If it is found that during a calibration there is insufficient adjustment then it is probable that there is a problem with either the calibration procedure, or a fault with the instrument, sensor or cabling. The most common causes of inaccurate conductivity readings are contaminated electrode surfaces and air trapped within the cell. Both of these will always give a low conductivity (high resistivity) reading. Refer to the sections in this Appendix on Care and Maintenance and Installation of Conductivity Cells for more information.

17.2 Calibration of Conductivity or Resistivity Readings

Conductivity measurements are very temperature dependent so it is essential that an understanding of the complex relationship between conductivity and temperature is understood when calibrations are made. It is possible to make several different types of calibration.

17.3 Resistance calibration of the instrument only

This is the most accurate method of calibrating the instrument but it will not take into account any variations due to the cell constant variation or coatings of contaminants. Calibration is at a single point only so a value close to the normal operating conditions is preferable. The resistance should be connected between the C and E terminals. (See the table of values at the end of this Appendix). It is recommended that any **extended lengths of cell cable** are left in during this calibration, as cable resistance will have some effect on the overall calibration accuracy. This is increasingly significant at high values of conductivity (low resistivity).

The temperature compensation must be switched out when making these adjustments and the relevant cell constant noted. The resistance accuracy will determine the overall accuracy of the calibration. A non-inductive resistance must be used below 100 ohms.

LTH can provide a conductivity simulator with traceable certification to perform this calibration. A table of values for specific calibration points is given at the end of this Appendix.

17.4 Calibration with Standard Solutions

This calibration must be carried out under strictly controlled conditions due to the temperature effect on conductivity measurements and the possibility of contamination of the standard solution. The advantage of this calibration method is that the sensor and cable are an integral part of the calibration. LTH strongly recommends a lower limit of 500 μ S/cm for this type of calibration. Conductivity is a very sensitive measurement and even trace contamination of the standard solution will be detected, for example exposing the solution to air will add 1 μ S/cm to the standard solution due to absorption of CO₂.

Most standards are made up from a solution of KCl dissolved in high purity water. BS 6438 provides details of the concentrations of KCl necessary to produce industry standard conductivity solutions. Ready made solutions are available from LTH with traceable certification if required.

Standard solutions will be supplied with a conductivity value quoted at a reference temperature. This temperature is the base temperature and the calibration should be performed at that temperature, with the temperature compensation switched out. Alternatively, the temperature compensation should be switched on and a temperature slope and base temperature equal to that of the calibration solution can be used to configure the instrument. For example this would be 1.76%/°C for a KCl solution between 1000 to 10,000 μ S/cm. For more details on calculating the slope of a different solution, refer to Appendix F.

17.5 Calibration by Comparison with Another Instrument

This can provide the easiest method for in-situ calibrations but does have the disadvantage of only being able to check a single measurement point. LTH recommends this method for ALL pure water (<10 μ S/cm) calibration checks and has developed a portable system specifically for this purpose. As measurements are made by comparison of the readings taken in the same solution, temperature effects are less critical. However, it is essential that settings for temperature compensation are the same on both instruments. For more information on the measurement of pure water refer to Appendix C.

17.6 Calibration of the Cell Constant

LTH conductivity cells are supplied with a nominal cell constant value, e.g 0.1, 1.0. The actual cell constant could be up to $\pm 2\%$ from this value. It is possible for LTH to measure the actual cell constant of each cell and provide traceable certification. The user can then program this value into the instrument eliminating the errors contributed by manufacturing variations in the cell geometry.

For the cell constants of 0.1 & 0.01 this is in the Calibration menu. For all values other than 0.1 & 0.01, this is achieved in the Parameters menu.

17.7 Care and Maintenance of Conductivity Sensors

Conductivity measuring systems are designed to be trouble free in use and reliable measurements can be expected during their operating life. However, some maintenance is required. In particular, the cell and cable connections should be checked for security and freedom from corrosion. The sensor will also require periodic cleaning, depending on the quality of the water passing through it and the type of sensor employed. A dirty sensor will always give a low conductivity reading.

The area of the cell which is sensitive to fouling is the electrode surfaces which must fully wet to ensure accurate measurements. Moulded cells are often used in applications where a high level of contamination may be expected.

Some of these contaminants do not contribute directly to the measured conductivity, e.g. organics, rust and suspended solids, but may form deposits on the electrode surface. In general these may be cleaned with the bristle brush provided and a weak detergent solution mixed with scouring powder.

Problems may occur in hard water areas where the gradual formation of scale will reduce the active area of the electrodes. Simple brush cleaning alone will not remove a hard deposit from the electrode surface. If scaling is suspected the cell should be removed from the system and treated with a 10% solution of hydrochloric or formic acid. The presence of bubbles will indicate that scale is being dissolved. Cleaning is completed when bubbles cease and usually takes 2-3 minutes. The cell must be thoroughly rinsed to remove all traces of acid before it is replaced in the system.

Note: Follow the suppliers data sheet when handling acids and dispose of as instructed by your local authority regulations.

Cells with stainless steel electrodes are generally used in applications where a low conductivity is combined with a low level of organic contamination and cleaning is rarely necessary. Errors in measurements can often be traced to faulty connections or incorrect setting on the instruments. However if contamination is suspected the cell should be removed from the system and cleaned if necessary.

Handling of the cell electrodes will leave residues of oils and greases which will affect the wetting of the surfaces, leading to inaccurate readings. After touching the electrodes, wash them with a weak detergent solution and rinse thoroughly. After rinsing check that the surfaces 'wet' properly, that is, they maintain a complete film of water for approximately 10 seconds.

17.8 Installation and Choice of Conductivity Sensors

The choice of the correct type of conductivity sensor, how and where to mount it, so that it has a representative sample of solution are probably the two most important considerations when installing a conductivity system.

The following criteria are of great importance during selection:

Appendix C - Calibration

- The choice of the best method of measurement
- Selection of the correct (optimum) cell constant
- Use of the correct materials for corrosion resistance
- Position of sensor for robustness and service access
- Ensuring a representative, uncontaminated solution sample

The following tips might be useful. The range of measurement will determine the cell constant. The epoxy resin castings are extremely resistant to most acids and alkalis. A number of sensors have stainless steel bosses and these should be avoided in the presence of chlorides, e.g. HCl.

There is also a growing tendency to passivate new pure water systems during commissioning, it is imperative that any sensors are removed from the pipework prior to this because it forms a non-conductive coating on the surface of the electrodes.

To ensure correct sensor mounting, observe the following:

- The solution between the cell electrodes or around the sensor must be representative of the solution as a whole.
- A moderate flow must be maintained to ensure an up to date sample. Excessive flow rates, however, can cause cavitation and turbulence within the sensor, which will result in inaccurate readings.
- The sensor must be mounted so that air bubbles do not lodge within it - displacing solutions and affecting the sample volume (air is not conductive).
- Similarly the sensor must be positioned so that sludge and particulate matter does not collect within the sensor.
- Conventional conductivity cells can suffer problems associated with direct electrical contact with the solution where large electrical currents may be flowing, for example in electroplating tanks.

It is not uncommon for a cell to require cleaning on a weekly or daily basis, due to the nature of chemicals used and the presence of scale in hard-water areas, experience will determine the correct maintenance periods.

17.9 Table of calibration resistance values

Conductivity Display Reading	Nominal cell constant K=0.01	Nominal cell constant K=0.1	Nominal cell constant K=1.0	Resistivity Display reading
0.050 $\mu\text{S/cm}$	200K			20.00 $\text{M}\Omega\text{-cm}$
0.100 $\mu\text{S/cm}$	100K			10.00 $\text{M}\Omega\text{-cm}$
0.200 $\mu\text{S/cm}$	50K			5.00 $\text{M}\Omega\text{-cm}$
0.500 $\mu\text{S/cm}$	20K			2.00 $\text{M}\Omega\text{-cm}$
1.000 $\mu\text{S/cm}$	10K	100K		1.00 $\text{M}\Omega\text{-cm}$
2.000 $\mu\text{S/cm}$	5K	50K		500 $\text{K}\Omega\text{-cm}$
5.000 $\mu\text{S/cm}$	2K	20K		200 $\text{K}\Omega\text{-cm}$
10.00 $\mu\text{S/cm}$	1K	10K	100K	100 $\text{K}\Omega\text{-cm}$
20.00 $\mu\text{S/cm}$	500R	5K	50K	50.00 $\text{K}\Omega\text{-cm}$
50.00 $\mu\text{S/cm}$	200R	2K	20K	20.00 $\text{K}\Omega\text{-cm}$
100.0 $\mu\text{S/cm}$	100R	1K	10K	10.00 $\text{K}\Omega\text{-cm}$
200.0 $\mu\text{S/cm}$		500R	5K	
500.0 $\mu\text{S/cm}$		200R	2K	
1000 $\mu\text{S/cm}$		100R	1K	
2.000 mS/cm			500R	
5.000 mS/cm			200R	
10.00 mS/cm			100R	
20.00 mS/cm			50R	
50.00 mS/cm			20R	
100.0 mS/cm			10R	
200.0 mS/cm				
500.0 mS/cm				
1000 mS/cm				

This list of calibration resistance values will allow the user to check or modify the calibration of the instrument. Temperature compensation **MUST** be turned off during the test or adjustment.

18 Appendix D – Ultra Pure Water

18.1.1 UPW cell positioning, flow rate and sampling

This summary of ASTM D5391-93, combined with LTH application notes applies to ultra-pure water applications only. These applications are very specific in nature and require great care to avoid errors in measurement.

Pure water conductivity or resistivity must be measured with a cell and temperature sensor in a flowing, closed system to prevent trace contamination from wetted surfaces and from the atmosphere.

Specialised temperature compensation can be used to correct the measurement to a reference temperature of 20 or 25°C taking into account the temperature effects on the ionisation of water, the contaminants and interactions between the two.

The cell constant for the precision cell has been determined with a secondary standard cell that has a cell constant determined by ASTM D1125.

Conductivity or resistivity can be used for detecting trace amounts of ionic contaminants in water. It is the primary means of monitoring the performance of demineralisation and other high purity water treatment operations.

It is used to detect ionic contamination in boiler waters, microelectronics rinse waters, pharmaceutical process waters and to monitor and control the level of boiler and power plant cycle treatment chemicals.

Exposure of the sample to atmosphere will cause changes in the conductivity or resistivity due to loss or gain of dissolved gases. CO₂ can reach an equilibrium concentration in water of about 1 mg/l and add up to 1 µS/cm to the conductivity due to the formation of carbonic acid. This process is quite fast, depending upon conditions.

Cell, flow chamber and sample line surfaces will slowly leach trace ionic contaminants, evidenced by increasing conductivity readings with very low or zero flow rate. There must be sufficient flow to keep these contaminants from accumulating to the point where they can significantly affect the measurement. The large and convoluted surface of platinised cells precludes their use for high purity measurements for this reason.

Samples containing dissolved gases must have sufficient flow through the cell so that bubbles cannot accumulate and occupy sample volume within the cell, causing low conductivity (high resistivity) readings.

High purity conductivity measurement must not be made on a sample downstream of pH sensors due to the possible contamination of the sample with traces of reference electrolyte salts. Use a dedicated sample line or place the conductivity cell up stream from the pH sensors.

Conductivity cells mounted downstream from ion exchangers are vulnerable to catching ion exchange resin particles between the cell electrodes.

Resin particles are sufficiently conductive to short circuit the cell and cause high off scale conductivity or extremely low resistivity readings.

Resin retainers must be effective and the cell must be installed so that it is accessible for cleaning. If this is a problem with the CMC68/001/PT43 cell use the CMC34/001/PT43 with the wall-mounted unit, which has wider spaced electrodes of greater than 1.5 mm. This has been found to be less likely to trap such particles.

Conductivity cells if subjected to de-mineraliser regeneration reagents require excessive rinse time to obtain satisfactory results, therefore, locate the cell where it will be isolated during regeneration. The cell should not be used to measure high ionic content samples of greater than 20 $\mu\text{S}/\text{cm}$ (less than 0.05 $\text{M}\Omega\cdot\text{cm}$) since it can retain ionic contaminants and require excessive rinse down time for valid measurements.

The instrument incorporates an electronic guard to minimise the effect of cable capacitance and a 4 wire temperature measurement system to allow accurate measurements. LTH 54G or similar cable must be used to ensure correct operation.

The cell must be located in an active flowing part of the piping. Stagnant areas or dead legs must be avoided to ensure a representative sample and prevent any bubbles from adhering to the cell surfaces.

Sample lines must be designed to maintain sample integrity. Do not expose the sample to atmosphere to prevent absorption or loss of gases, particularly CO_2 which will affect conductivity.

The sample should be continuous at a stable flow rate of at least 100 ml/min and should be maintained to enable sample line wetted surfaces to reach equilibrium with sample conditions. Do not make measurements following changes to sample flow rate for the period of time required to recover from transient effects on the particular sampling system.

19 Appendix E – Temperature Coefficient

19.1 Calculating the temperature coefficient of a solution

If the temperature coefficient of the solution being monitored is not known, the HCT63 can be used to determine that coefficient. You should set the HCT63 to a suitable range and the temperature coefficient to 0.0%.

The following measurements should be made as near to the normal operating point as practical, between 5°C and 70°C for the highest accuracy. Immerse the measuring cell in at least 500 ml of the solution to be evaluated, allow sufficient time to stabilise, approximately one or two minutes, and then record both the temperature and conductivity readings. Raise the solution temperature by at least 10°C and again record the temperature and conductivity readings. Using the following equation, the temperature compensation slope can be calculated in percentage terms:

$$\alpha = \frac{(G_x - G_y) \times 100\%}{G_y(T_x - 25) - G_x(T_y - 25)} \quad (\text{base temperature } 25^\circ\text{C})$$

Note: If base temperature is set to 20°C, then replace 25 with 20 in the above equation.

Term	Description
G_x	Conductivity in $\mu\text{S/cm}$ at temperature T_x
G_y	Conductivity in $\mu\text{S/cm}$ at temperature T_y

Note: One of these measurements can be made at ambient temperature.

Set the temperature compensation slope to the calculated value. The temperature compensation is now set up for normal operation.

If it is difficult or impossible to evaluate the temperature compensation slope using this method, a 2.0 % / °C setting will generally give a good first approximation until the true value can be determined by independent means.

20 Appendix F – Temperature Data

The table below lists approximate resistance values of temperature sensors that may be used with the HXT63 series. Not all options are available on all models.

Temperature (°C)	PT1000 RTD	PT100 RTD	1K Thermistor	3K Balco
0	1000.0Ω	100.00Ω	2691Ω	2670Ω
10	1039.0Ω	103.90Ω	1779Ω	2800Ω
20	1077.9Ω	107.79Ω	1204Ω	2930Ω
25	1097.3Ω	109.73Ω	1000Ω	3010Ω
30	1116.7Ω	111.67Ω	833.7Ω	3070Ω
40	1155.4Ω	115.54Ω	589.0Ω	3160Ω
50	1194.0Ω	119.40Ω	423.9Ω	3320Ω
60	1232.4Ω	123.24Ω	310.5Ω	3470Ω
70	1270.7Ω	127.07Ω	231.0Ω	3570Ω
80	1308.9Ω	130.89Ω	174.5Ω	3740Ω
90	1347.0Ω	134.70Ω	133.6Ω	3830Ω
100	1385.0Ω	138.50Ω	103.6Ω	4020Ω

21 Appendix G – Save / Restore

21.1 Saving and Restoring Set-up Data

The instrument can be set up to save and restore data as a safeguard against accidental erasure of some or all of the programmed data.

There are three banks of data that can be interchanged as required.

- **Working Data:** the operating data and set-up parameters that are used by the instrument and which can be changed or viewed on the display by the user.
- **Primary backup:** the A stores can be written to or read back as a block of data. Data in these stores cannot be viewed without first loading it into the Working data stores. This read back will overwrite the existing Working data, leaving the A store data unchanged.
- **Secondary backup:** the B stores can be written to or read back as a block of data. Data in these stores cannot be viewed without first loading it into the Working data stores. This read back will overwrite the existing Working data, leaving the B store data unchanged.

When an individual parameter is saved, the corresponding data is copied into a single non-volatile memory location. (This simply means the data is not lost when the power is removed or interrupted.)

When a complete programme sequence or set-up has been entered into the Working data stores, the whole set-up can be copied (using Save/Restore) into either the A or B stores. We strongly recommend that this feature is used.

It is also possible to restore the default parameters. This can be useful for fault finding, since a working configuration can quickly and easily be programmed in to aid commissioning or testing the instrument. Remember to Save the normal set-up first and restore it afterwards.

If corruption of data is reported by the software with an error message, the saved set-up can be copied back into the Working stores from either the A or B stores.

22 Appendix H – Error Messages

Switch On Diagnostic Errors

E01	Processor RAM Read/Write Error Try switching the unit off then on again. If the message persists, consult with your supplier, as this unit will require to be returned for repair.
E02	Reserved for future use
E03	PSD RAM Read/Write Error Try switching the unit off then on again. If the message persists, consult with your supplier, as this unit will require to be returned for repair.
E04	Setup Checksum Error The instrument configuration has for some reason become corrupted. Restore a setup from store A or B, or one of the two default setups.
E05	Store A Checksum Error The data in setup store A has been corrupted. Save the current setup back to store A.
E06	Store B Checksum Error The data in setup store B has been corrupted. Save the current setup back to store B.
E07	Factory Calibration Checksum Error The factory calibration data for this instrument has been corrupted. The instrument will need to be re-calibrated. Consult your supplier.
E08	User Calibration Checksum Error The user calibration data has been corrupted. Reset the user calibration and re-enter
E11	Zero Cal Sensor zero calibration is faulty.
E12	Span Cal Sensor span calibration is faulty.
E13	Min Temp Cal Temperature zero calibration is faulty.
E14	Max Temp Cal Temperature span calibration is faulty.

Appendix H – Error Messages

E15-18	Reserved for future use.
---------------	--------------------------

E21-28	Not used.
---------------	-----------

Sensor Input Errors

E31	Sensor OC The sensor input at open circuit
E32	Sensor SC The sensor input at short circuit
E33	Sensor Input Over-range The sensor input over the specified range
E34	Sensor Input Under-range The sensor input is under the specified range
E35	Temperature Sensor Fault The temperature sensor is reading open or closed circuit, due in most cases to a damaged sensing element or incorrect wiring. Check Configuration menu Temperature Sensor is set to the correct type. Under this condition, the unit will default to the fixed temperature setting for compensation purposes.
E36	Temperature Input Over-range Temperature input is greater than +300.0°C
E37	Temperature Input Under-range Temperature input in less than -50.0°C Temperature
E38	Compensation Outside Limits The temperature reading is less than 0.0°C or greater than 100.0°C, leading to an error in compensation.

Current Output Errors

E41	Current Output A Hardware Fault The current output circuit has detected an error in the output. This is most commonly due to either a broken loop or too large a load resistor. It can also be caused by insufficient supply voltage for the load (see <i>Section 3.3.1 Power Supply</i>).
E42	Current Output B Hardware Fault The current output circuit has detected an error in the output. This is most commonly due to either a broken loop or too large a load resistor. It can also be caused by insufficient supply voltage for the load (see <i>Section 3.3.1 Power Supply</i>).
E43	Sensor Input < Current OP A Zero Level The sensor input level is below that set for current output A zero.
E44	Sensor Input > Current OP A Span Level The sensor input level is above that set for current output A span.
E45	Sensor Input < Current OP B Zero Level The sensor input level is below that set for current output B zero.
E46	Sensor Input > Current OP B Span Level The sensor input level is above that set for current output B span.

Floating Point Maths Errors

These errors are only flagged when an internal maths calculation fails. As such, they should not appear if the software is functioning properly. The error message should time out after approx. 5 seconds. If the error continues to be displayed, call LTH or an authorised distributor for advice.

E51	Overflow Error
E52	Underflow Error
E53	Divide by 0 Error
E54	Too Large For Conversion
E55	Too Small For Conversion

Appendix H – Error Messages

Index

Access		Input source	28
Code	19	Output range	28
Entry	19	Range	13
Levels	19	Zero & Span	29
Accuracy	1	Default setups	40
Alarm	27	Digital inputs	2, 13
Alarm mode	2	Display	14
Autoranging	13, 22	Dose alarm	2, 26, 27, 40, 41, 43, 44
Averaging	34	email	i
Bargraph	34	EMC	ii
Bell Symbol	17, 38	EMI	5
Cable	36, 37	Error	29
Screen	37	Error message	17, 18, 34, 35, 55
Calibration	30, 42	Fault Finding	35
Best Practice	45	Fax	i
Current output	31	Filtering	34
Resetting	32	Guarantee	39
Temperature	31	Input filtering	34
Calibration alarm	27	Installation	6
Cell Cable	45	Interference	5
Cell constant	1, 3, 21, 31	Key Symbol	19
Conductivity cells	1	Keys	15, 19
Configuration	16, 17, 42	Language	33
Connections	9	LCD	14
Current output	12	LEDs	14
Digital inputs	13	LVD	ii
Relays	12	Main Display Menu	18
Copyright	i	Menu system	15
Current output	2, 28, 42	Noise filtering	34
Calibration	31	Noise suppression	5
Connections	12	Off-line	2, 14, 27, 30

Appendix H – Error Messages

Alarm	27	Range	13, 24
On-line	30	Relay	23
Output current	18	Source	24
Padlock Symbol	19	TP Mode	25
Parameters	20	Trigger	24
Proportional band	25, 26	USP26	26
Proportional control	29	Simulated Input	22
Proportional mode	2	Software version	34
Pt1000	36	Solution conversion	50
Quality	ii	Standards	ii
Range	1, 3, 13	System error	27
Customer Set Up	43	TDS	3
Default	40	Telephone	i
Set Point	24	Temperature	
Relay	23	Calibration	31
Relay connections	12	Coefficient	52
Remote warning	29	Compensation	21, 37
Returns	39	Fixed	21
RFI	5	Input	21
RTD	36	Sensor	33
Safety	ii	Sensor Data	53
Saving and restoring	54	Units	21
Secondary parameter	18	Tests	35
Self diagnostic tests	35	Timeout	15
Sensor error	27	Units	
Set point	18, 23, 40	Sensor	20
Delay	25	Temperature	21
Dose alarm	26	USP26	20, 24, 26, 32
Hysteresis	25	Warranty	i, 39
On/Off Mode	25	Wiring	4, 9
PP Mode	26		

Sensor & temperature	ACCESS CODE	PARAMETERS	SETPOINTS 1&2	¹ CURRENT OUTPUT	CALIBRATION	SAVE / RESTORE	CONFIGURATION
↑ ↓ Sensor & current O/P A	↑ ↓ Edit Level 1 access code	↑ ↓ Display units	↑ ↓ SP1 source	↑ ↓ O/P A source	↑ ↓ Online / offline	↑ ↓ Save as Setup A	↑ ↓ ² Language
↑ ↓ Sensor & current O/P B	↑ ↓ Edit Level 2 access code	↑ ↓ Cell constant	↑ ↓ SP1 range	↑ ↓ O/P A mode (0/4-20 mA)	↑ ↓ Sensor calibration	↑ ↓ Save as Setup b	↑ ↓ Temperature sensor
↑ ↓ Sensor & set point 1 *	↑ ↓	↑ ↓ Range	↑ ↓ SP1 trigger	↑ ↓ O/P A range	↑ ↓ Temperature calibration	↑ ↓ Restore Setup A	↑ ↓ Error messages
↑ ↓ Sensor & set point 2	↑ ↓	↑ ↓ TDS factor	↑ ↓ SP1 level (band high)	↑ ↓ O/P A zero	↑ ↓ Cell K adjust	↑ ↓ Restore Setup B	↑ ↓ Input filter
↑ ↓		↑ ↓ Temperature units	↑ ↓ SP1 band low	↑ ↓ O/P A span	↑ ↓ Current O/P A calibration	↑ ↓ Restore default conductivity	↑ ↓ Bargraph on/off
OR		↑ ↓ Temperature compensation	↑ ↓ SP1 mode	↑ ↓ O/P B source	↑ ↓ Current O/P B calibration	↑ ↓ Restore default resistivity	↑ ↓ Software issue
Bargraph		↑ ↓ TC base	↑ ↓ SP1 dose alarm	↑ ↓ O/P B mode (0/4-20 mA)	↑ ↓ Reset user calibration	↑ ↓ Restore default USP26	↑ ↓
		↑ ↓ TC slope	↑ ↓ SP1 delay	↑ ↓ O/P B range			
		↑ ↓ TC mode	↑ ↓ SP1 hysteresis	↑ ↓ O/P B zero			
		↑ ↓ Manual temperature	↑ ↓ SP1 cycle time	↑ ↓ O/P B span			
Key:		↑ ↓ Sim Current OutA	↑ ↓ SP1 proportion band	↑ ↓ Source error			
Universal access		↑ ↓ Sim Current OutB	↑ ↓ SP2 source	↑ ↓			
Level 1 access		↑ ↓	↑ ↓				
Level 2 access			Etc, as SP1				

Notes :

1. The Current Output menu will only appear when the unit is configured for Current Outputs.

2. The Language option is not available on some (English-only) units.

3. Depending on unit settings, some menu items may not appear. (See the appropriate sections in the main text.)

LTH Electronics Ltd

Chaul End Lane
Luton
Bedfordshire
LU4 8EZ
United Kingdom

Telephone : +44 (0) 1582 593693
Fax : +44 (0) 1582 598036
e-mail : sales@lth.co.uk
web : www.lth.co.uk