

AquaCal 2000

PURE WATER CONDUCTIVITY METER

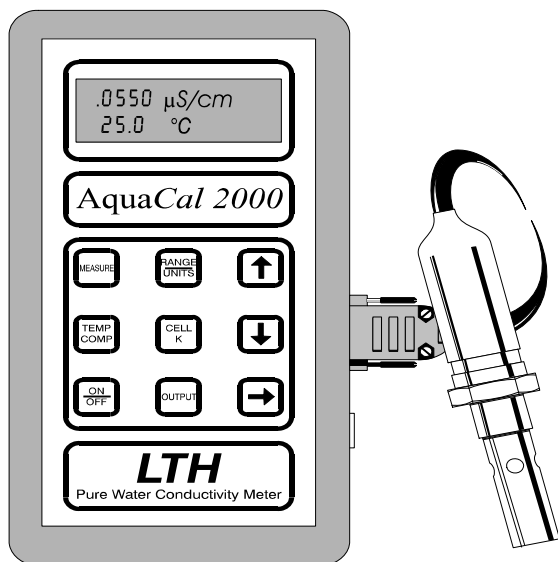

OPERATION GUIDE

Preface

Product warranty

This guide, together with its associated software media and hardware, has a warranty against defects in materials and workmanship for a period of three years from the date of shipment. During this period LTH will, at its own discretion, either repair or replace products that prove to be defective. The associated software is provided 'As is' without warranty.

Limitation of warranty

The foregoing warranty does not cover damage caused by accidental misuse, abuse, neglect, misapplication or modification.

No warranty of fitness for a particular purpose is offered. The user assumes the entire risk of using the product. Any liability of LTH is limited exclusively to the replacement of defective materials or workmanship.

There are no user serviceable parts, including fuses etc., within the unit. Any attempt to dismantle the instrument will invalidate the warranty.

Disclaimer

LTH Electronics Ltd reserves the right to make changes to this manual or the instrument without notice, as part of our policy of continued developments and improvements.

All care has been taken to ensure accuracy of information contained in this manual. However we cannot accept responsibility for any errors or damages resulting from errors or inaccuracies of information herein.

Copyright and trademarks

All rights reserved. Translations, reprinting or copying by any means of this manual, complete or in part or in any different form requires our explicit approval.

AquaCal 2000 is a trademark of LTH Electronics Ltd.

This guide was produced by Electrotech Services, 01245 471589

Third edition May 2014

Part number: 6129

LTH Electronics Ltd

Chaul End Lane

Luton

Bedfordshire

LU4 8EZ

England

Telephone : +44 (0)1582 593693

Fax : +44 (0)1582 598036

Email : sales@lth.co.uk

Web : www.lth.co.uk

Standards

Electromagnetic compatibility

This instrument has been designed to comply with the standards and regulations called up by the European Directive on EMC



Safety

This instrument has been designed to comply with the IEC 348-1978 (BS 4743-1979) safety standard to Protection Class 1.

Quality

This instrument has been manufactured under the following quality standard: ISO 9001:2000. Certificate No: FM 13843

Note: The standards referred to in the design and construction of LTH products are those prevailing at the time of product launch. As the standards are altered from time to time, we reserve the right to include design modifications which are deemed necessary to comply with the new or revised regulations.

Contents

1 Introduction	1-1
Traceable calibration	1-1
AquaCal 2000 functions	1-1
Analogue outputs	1-3
Specifications	1-4
2 Installation	2-1
Cells and sampling	2-1
Connections and cabling	2-1
D-connector Cell & Pt1000	2-6
D-connector - Battery charger and voltage outputs	2-6
D-connector - Mounted on battery charger for voltage outputs	2-6
3 Operation	3-1
Viewing the readings	3-1
Viewing the AquaCal 2000 settings	3-2
4 Setting Up	4-1
Security setting	4-1
Range and units	4-2
Units	4-2
Range	4-4
Temperature compensation	4-5
Cell constant	4-6
Output	4-7
Temperature output	4-7
Conductivity output	4-9
Error messages, auto power off and input filter	4-10

5	Fault Finding	5-1
	Introduction	5-1
	Faults	5-2
	Instrument appears dead	5-2
	Instrument display appears to malfunction	5-2
	Unable to program the instrument	5-2
	Membrane switch panel appears to malfunction	5-2
	Conductivity reading appears incorrect	5-2
	Temperature reading appears incorrect	5-3
	Voltage outputs appear incorrect or noisy	5-4
	Error messages	5-4
	General	5-5
	System setup and operations	5-6
	Conductivity/resistivity voltage output operations	5-6
	Temperature voltage output settings	5-7
	Analogue calibration operations	5-7
	Floating-point mathematical routines	5-8
	EEPROM checksums	5-9
6	Guarantee and service	6-1
	Appendix A Cell positioning, flow rate and sampling	A-1
	Appendix B Calculating the temperature coefficient of a solution	B-1
	Index	
	Quick Reference	

1 Introduction

The *AquaCal 2000* is a handheld microprocessor based unit which allows measurement to traceable standards. It measures the conductivity or resistivity of an aqueous solution and gives a direct digital readout. The instrument can be set to operate on a single fixed range or with full auto ranging.

Two voltage outputs for remote monitoring or recording are available.

Traceable calibration

The *AquaCal 2000* offers no user calibration: the instrument is factory calibrated to traceable standards. The cell provided is also calibrated to traceable standards and has a certified cell constant. The cell constant is the only user adjustable parameter and the user must ensure that the cell constant entered on the instrument matches that of the cell used. The cell constant programmed into the instrument must be changed if a different cell is to be used.

AquaCal 2000 functions

The front panel of the *AquaCal 2000* provides a direct digital readout of the solution conductivity or resistivity and temperature.

The instrument's operations are controlled with nine tactile membrane key switches. These switches select the information to be displayed, and allow the configuration parameters to be entered or edited. If desired, the parameters can be protected from casual tampering with a coded security setting.



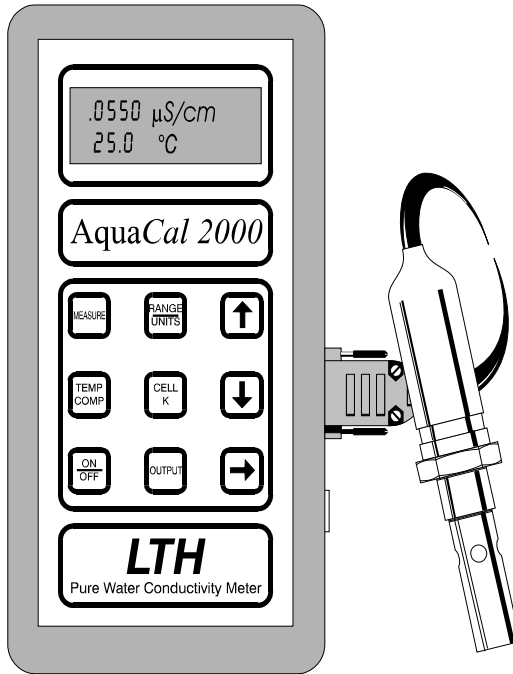



An input filter can be selected that averages measurements over a few seconds to provide a more stable display. An Auto Power Off facility can be set to turn off the unit if no keys are pressed for a preset period of time. In the event of an error, an error message may be displayed; this message display can be turned on or off, as required.



The following table summarises the functions provided by each key. In some cases, further functions can be reached by pressing .

Key	Description
ON/OFF	Switches the unit ON or OFF
MEASURE	Displays the conductivity/resistivity and temperature.
RANGE/UNITS	Displays the range and units and allows changes to be made.
TEMP.COMP.	Allows the temperature compensation to be turned on or off and the compensation slope to be set between 0.0 and 3.9%/°C. The base temperature can be set to either 20 or 25°C.
CELL K	Displays the cell constant and allows it to be changed.
OUTPUT	Displays the voltage output settings and allows them to be changed (if fitted).

The following functions are obtained by pressing two keys simultaneously.

Keys	Followed by	Description
 		Displays the error messages flag and allows them to be set IN (messages displayed) or OUT (not displayed).
		Displays and allows changing of the Auto Power Off time.
		Displays and allows selection/deselection of the input filter.
 		Prompts the user to enter a security code; if code is entered correctly, user can lock or unlock instrument settings.

Analogue outputs

Two 0-1V DC analogue signals are provided. They share a common 0V but are electrically isolated from the cell, power supply and case. These outputs offer user scaleable offset and span up to a maximum of 10% of range. The voltage outputs allow remote monitoring for applications where additional readouts or recording of conductivity/resistivity and temperature are required.

Specifications

Ranges of measurement	Conductivity	Resistivity	Temperature
	0 - 0.9999 $\mu\text{S/cm}$	0 - 999.9 $\text{K}\Omega.\text{cm}$	-10.0 - +110.0 $^{\circ}\text{C}$
	0 - 9.999 $\mu\text{S/cm}$	0 - 9.999 $\text{M}\Omega.\text{cm}$	
	0 - 99.99 $\mu\text{S/cm}$	0 - 99.99 $\text{M}\Omega.\text{cm}$	
	0 - 9.999 $\mu\text{S/m}$		
	0 - 99.99 $\mu\text{S/m}$		
	0 - 999.9 $\mu\text{S/m}$		
	0 - 9999 $\mu\text{S/m}$		
	User selectable or full auto ranging		
Temperature compensated system accuracy, including linearity and repeatability	0.3% of range	0.3% of range	0.1 $^{\circ}\text{C}$
Ambient temperature	0-50 $^{\circ}\text{C}$		
Ambient temperature variation	0.01% of range/ $^{\circ}\text{C}$ (typical)		
Temperature compensation	Fixed curve compensation for ultra pure water. Selectable slope of 0.0 to 3.9%/ $^{\circ}\text{C}$ for the impurity contribution.		
Temperature compensation base	Selectable 20 $^{\circ}\text{C}$ or 25 $^{\circ}\text{C}$		
Display	16 x 2 character alphanumeric LCD		
Cell constant range	Adjustable 0.01000 \pm 10%		
Operating frequency	70Hz		
Voltage outputs	2 off 0 - 1V DC isolated into a minimum load of 10K Ω for conductivity or resistivity and temperature. User scaleable offset and span up to a maximum of 10% of range.		

Battery type	4 x AA alkaline or NiCad rechargeable	
Battery life	40 hours continuous with alkaline batteries. NiCad batteries have typically half this life.	
Recharge time	24 hours from flat	
Low battery warning	By a symbol on the display 	
Auto power off	Selectable, 1 minute to 40 hours, or disabled.	
Security	Access code entered on the front panel.	
Electromagnetic compatibility	Immunity IEC 801-2 to Level 4. IEC 801-3 to Level 3. IEC 801-4 to Level 3. IEC 801-5 (Draft) to Level 1. IEC 801-6 Pending.	
Environmental protection	To IP65	
Dimensions	Instrument 195x101x44 mm	Carrying Case 325x290x105 mm
Weight	0.6 kg	Less than 3 kg complete with cell, flow holder, battery charger and connection cables.

Cell type	CMC26/001/PT43
Cell constant	Nominally 0.01 supplied with traceable certification.
Cell cable length	Standard 2 metres. Maximum 5 metres
Temperature sensor	Pt1000

Battery Charger Supply	105-120 V or 200-250V AC 50-60 Hz (specify when ordering)
Battery Charger output	12V DC, 100mA max



This instrument complies with current European Directives

2 Installation

Cells and sampling

Refer to Appendix A for extracts from ASTM D5391-99 referring to cell positioning, flow rate and sampling.

Although other cells can be used with the *AquaCal 2000* instrument, the CMC26/001/PT43 allows measurement to traceable standards. To enable this, the cell is provided with a certified cell constant. The cell constant must be entered on the instrument to ensure accurate readings. A cell adapter cable to interface standard LTH C16 connectors is available. This will enable other LTH $K=0.01$ cells to be connected to the instrument:

CMC11/001/PT43 ; CMC15/001/PT43; CMC24/001/PT43 ;
CMC25/001/PT43 ; CMC34/001/PT43

When changing cells, it is imperative to enter the new cell constant on the instrument.

A stainless steel flow chamber is available to allow inline measurement (Figure 2). Install the cell in the flow chamber and divert some or all of the flow through the chamber by connecting it to the inlet and outlet ports of the chamber. Always use the bottom port as the inlet to ensure that the flow fills the chamber.

The flow chamber will stand on a flat surface (Figure 2). The user can also support it using the bracket supplied (Figure 3).

Connections and cabling

The CMC26/001/PT43 is fitted with a C16 connector and supplied with a separate 2 metre cable and a 9 way D-connector. An adaptor cable is available to allow other $K=0.01$ cells fitted with LTH C16 plugs to be connected to the instrument. LTH can make up special cables to interface with other manufacturers' cells of constant $K=0.01$. Only cells fitted with a Pt1000 RTD can be tested in temperature compensated mode.

A second D-connector is used for both the battery charger/power supply and the voltage outputs.

If the voltage outputs are to be used, a connector and screened cable with four flying leads is provided. Figure 3 shows the pin connections on the connector and the wire colours of the cable supplied.

Figure 5 shows the arrangement where a battery charger/power supply is used. In this case, the voltage output cable connects to the charger/supply unit instead of direct to the unit. Battery charger/power supply units are available for use on 110V AC and 230V AC; check the label on the unit before connecting it to the mains supply.

Note: Hosetail connectors and sealing washers are available as an optional extra. These will fit tubing of 1/4" I.D.

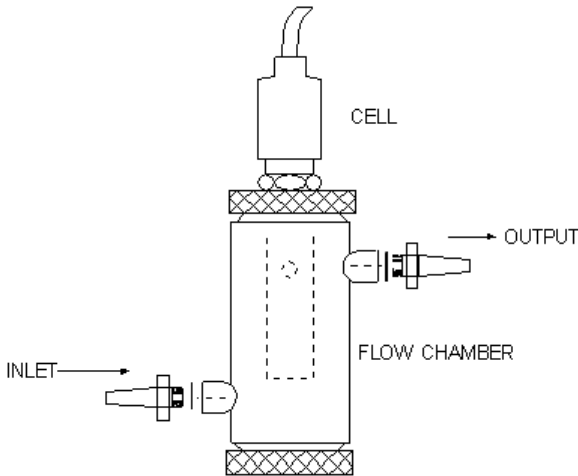

Figure 2 Flow chamber

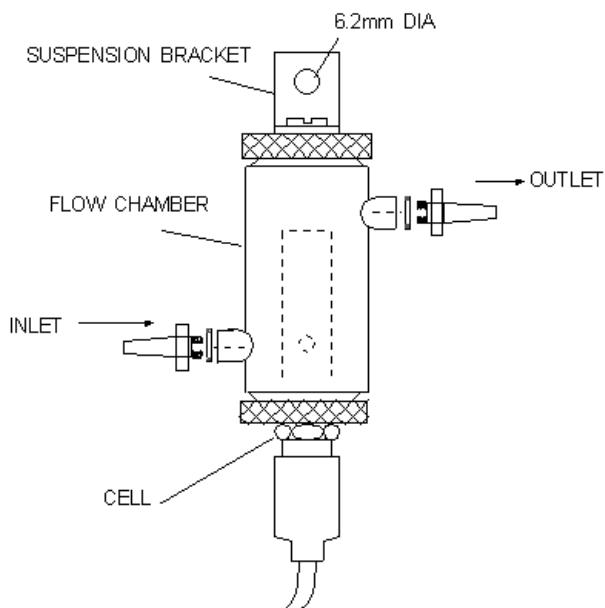

Figure 3 Suspended flow chamber

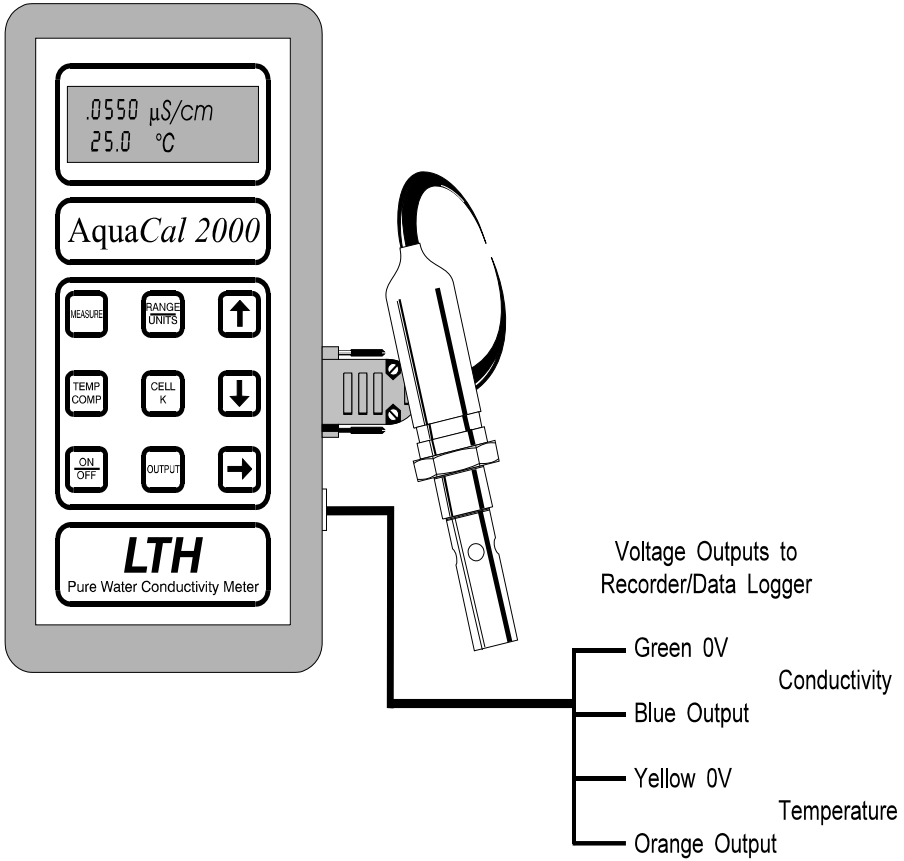

Figure 4 Connections for battery operation

See page 2-6 for wiring information.

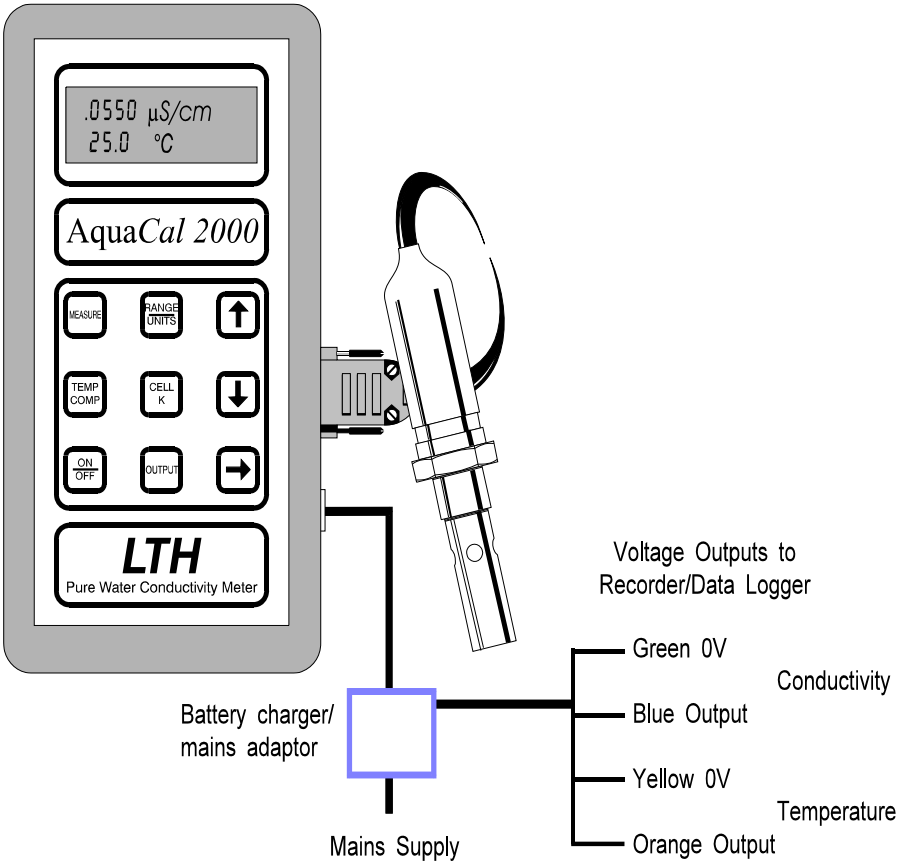

Figure 5 Connections for mains operation

See page 2-6 for wiring information.

D-connector Cell & Pt1000

- | | |
|------------------------|----------------|
| 1 C (centre electrode) | 6 G (guard) |
| 2 E (outer electrode) | 7 Earth/shield |
| 3 Earth/shield | 8 T4 |
| 4 T1 | 9 T3 |
| 5 T2 | |

T1 and T3 are connected to one side of the Pt1000.

T2 and T4 are connected to the other side of the Pt1000.

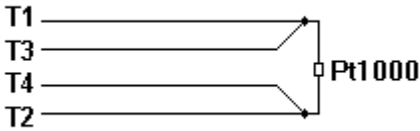

Note: the 4 wire connection to the RTD must be maintained for instrument accuracy.

D

D-connector - Battery charger and voltage outputs

- | | |
|-----------------------|--------------------------|
| 1 - 0-1V DC signal | 6 - 0-1V DC signal |
| 2 + output (cond/res) | 7 + output (temperature) |
| 3 Earth/shield | 8 Earth/shield |
| 4 - 12V DC instrument | 9 Earth/shield |
| 5 + supply | |

D-connector - Mounted on battery charger for voltage outputs

- | | |
|-----------------------|--------------------------|
| 1 - 0-1V DC signal | 6 - 0-1V DC signal |
| 2 + output (cond/res) | 7 + output (temperature) |
| 3 Earth/shield | 8 No connection |
| 4 No connection | 9 No connection |
| 5 No connection | |

3 Operation

This chapter explains the *AquaCal 2000* display and the operational functions available from the front panel membrane switches. The *AquaCal 2000* functions are selected using six operation keys in conjunction with the three modifier keys -

↑, ↓ and →.

The main functions are selected by pressing the corresponding key on its own. Subsequent presses of → will scroll through other displays where applicable. Some functions are also available by pressing two keys simultaneously.

When pressing a key, hold it down for about half a second or just long enough to produce the desired effect. Holding a key down for more than one second causes repeated action of the key function, where appropriate.

Displayed figures shown in **bold** are flashing.

Viewing the readings

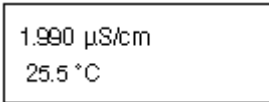











1.990 μS/cm
25.5 °C









Pressing MEASURE will return the display to this.

Note: The display always reverts to this display after 30 seconds, if no keys have been pressed.

Viewing the AquaCal 2000 settings

The following table shows the functions for viewing each of the AquaCal 2000 settings. In many cases, the operational key displays a sequence of settings which you step through by pressing .

To view	Press	Display shows (example)
Range and units		Range Units 9.999 $\mu\text{S/cm}$
Temperature Compensation		TC Base Slope In 25°C 2.0%/°C
Cell Constant		Cell Constant 0.01000
Conductivity Output Settings		Output : COND
		Output Range 9.999 $\mu\text{S/cm}$
		Zero Span 0.000 5.000 $\mu\text{S/cm}$
Temperature Output Settings		Output : COND
		Output : COND
		Output : TEMP

To view	Press	Display shows (example)
		Output : TEMP
		Zero Span 0.0 100.0 °C
Error Messages setting	 	Errors In (error messages displayed) or Errors Out (not displayed).
Auto off setting		Auto off Yes 0:10 Hh:Mm
Filter setting		Filter In (measurements averaged) or Filter Out (not averaged)
Security setting	 	0000 Out Enter Code

If you enter the correct security code, display will change to **Security Out** or **Security In**. Parameter settings can be altered if the security setting is **Out**. Refer to *Security setting* on page 4-1 for more details.

This page is intentionally left blank

4 Setting Up

This chapter describes the recommended procedure for setting up and configuring the *AquaCal 2000*.







When pressing a key, hold it down for about half a second or just long enough to produce the desired effect. Holding a key down for more than one second causes repeated action of the key function, where appropriate.

Displayed figures shown in **bold** are flashing.

Security setting







To prevent casual tampering with parameter settings, the instrument can be made secure. In order to lock or unlock the instrument, the user must enter a fixed security code (1582). The security setting can then be changed to In (locked) or Out (unlocked).

To change the security setting:

Press	Display shows (example)	Explanation
1  	0000 Out Enter code	The present setting of security is displayed in the top right corner
2  or 	0000 Out Enter code	The first digit flashes
3  or 	1000 Out Enter code	Increment or decrement the flashing digit. Set the first digit to '1'.
4 	1000 Out Enter code	The second digit will flash.

Repeat steps 3 and 4 to set the remaining digits to '5', '8' and '2'.

After entering the last digit, press  to confirm the displayed security code '1582' (this is the LTH area telephone code). If the code is incorrectly entered, the display will revert to '0000'.



Press	Display shows (example)	Explanation
5 	Security Out	Display change to allow user to change setting
6  or 	Security Out	The setting flashes
7  or 	Security In	Change the setting
8 	Security In	Enter the setting





Press MEASURE to leave the security screen.

Range and units

The ranges that are available (see page 1-4) depend on the units selected. Therefore if a change of units is required, these should be set first. After setting the units, the range is automatically set to Auto. You can then select the required fixed range from those available for the selected units.







Units

Press	Display shows (example)	Explanation
1 	Range Auto Units $\mu\text{S/cm}$	The present range and units are displayed
2  or 	Range Auto Units $\mu\text{S/cm}$	The range flashes













Press	Display shows (example)	Explanation
3 	Range Auto Units $\mu\text{S/cm}$	The units flash
4  or 	Range Auto Units $\text{M}\Omega.\text{cm}$	Change the units as required
5 	Range Auto Units $\text{M}\Omega.\text{cm}$	Enter the new units



If a range change is now required, follow the procedure for changing the range, omitting the first step.

Range



Press	Display shows (example)	Explanation
1  (If necessary)	Range Units Auto $\mu\text{S/cm}$	The present range and units are displayed
2  or 	Range Units Auto $\mu\text{S/cm}$	The range flashes
3  or 	Range Units 9.999 $\mu\text{S/cm}$	Set the range as required
4 	Range Units 9.999 $\mu\text{S/cm}$	The units flash
5 	Range Units 9.999 $\mu\text{S/cm}$	To scroll through

Temperature compensation

Press	Display shows (example)	Explanation
1 	TC Base Slope In 25°C 2.0%/°C	The present settings are displayed.
2  or 	TC Base Slope In 25°C 2.0%/°C	The T.C. In (or Out) flashes
Press  or  to change the T.C. status.		
3 	TC Base Slope In 25°C 2.0%/°C	Enter T.C. status and advance to base temperature
If Out is selected, the display clears and no further entry is necessary. If In is selected:		
4  or 	TC Base Slope In 20°C 2.0%/°C	Select 20 or 25°C
5 	TC Base Slope In 20°C 2.0%/°C	Enter the base temperature and advance to slope value
6  or 	TC Base Slope In 20°C 1.0%/°C	Set the first digit of the slope as required
7 	TC Base Slope In 20°C 1.0%/°C	Advance to the next digit

Press	Display shows	Explanation
8  or 	TC Base Slope In 20°C 1.9%/°C	Set the digit
9 	TC Base Slope In 20°C 1.9%/°C	Enter the slope value

Cell constant





Press	Display shows	Explanation
1 	Cell Constant 0.01000	The present setting is displayed
2  or 	Cell Constant 0.01000	The digit '1' flashes. This digit can only be set as either 1 or 0, as the cell constant can only be set between 0.00900 and 0.01100

Use  in conjunction with  and  to set the value of the cell constant.

When the last digit is flashing, press  to enter the new cell constant.





The unit will ignore an illegal cell constant entry; it will instead use and display the last legal entry.



Output

Press	Display shows (example)	Explanation
1 	Output : COND	
2  or 	Output : COND	COND flashes
3  or 	Output : TEMP	Toggles between TEMP and COND

The next screen depends on whether COND or TEMP is selected, see page 4-9 for COND settings.

Temperature output









Press	Display shows (example)	Explanation
4	Output : TEMP	TEMP flashes
5 	Output : TEMP	
6 	Zero Span 0.0 100.0°C	The present zero and span settings are shown
7  or 	Zero Span 0 00.0 100.0°C	Start the first digit flashing

Press	Display shows (example)	Explanation
8	 or 	Increment or decrement the flashing digit
9		Enter the flashing digit and move to the next digit

Repeat steps 8 and 9 for each digit of both zero and span values.

When the last digit is flashing, press  to confirm the settings.













Conductivity output







Press	Display shows (example)	Explanation
4	Output : COND	COND flashes
5	 Output : COND	
6	 Output Range 9.999 $\mu\text{S}/\text{cm}$	The present output range is displayed
7	 or  Output Range 9.999 $\mu\text{S}/\text{cm}$	
<p>Note: The conductivity output units must be the same as the measurement units. If the measurement units have been changed, the old units will be displayed, until  or  is pressed to flash the range. At this time, the units will automatically align with the measurement units.</p> <p>Note: Auto ranging is not available on the output range setting.</p>		
8	 Output Range 99.99 $\mu\text{S}/\text{cm}$	
9	 Zero Span 00.00 99.99 $\mu\text{S}/\text{cm}$	The present settings are displayed

To make alterations here, follow the procedure shown previously for adjusting the temperature output zero and span.

Error messages, auto power off and input filter

Note: Some of the following steps should be omitted where changes are not required to all of the settings.

	Press	Display shows (example)	Explanation
1		Errors In	Error messages will be displayed.
2	 or 	Errors In	In flashing.
3	 or 	Errors Out	Select In or Out to display error messages (In) or not (Out).
4		Errors Out	Enter setting
5		Auto off Yes 00:10 Hh:Mm	Instrument will switch off after 10 minutes if no key has been pressed.
6	 or 	Auto off Yes 00:10 Hh:Mm	Yes flashing. Toggle between Yes for automatic power off or No for none.
7		Auto off Yes 00 :10 Hh:Mm	Confirm Yes/No selection. If you select No , the time will not be adjustable.
8	 or 	Auto off Yes 10:10 Hh:Mm	Increment/decrement flashing digit.
9		Auto off Yes 10:10 Hh:Mm	Confirm digit selection.

Press	Display shows (example)	Explanation
	Repeat steps 8 and 9 for each digit. The data is entered into memory during step 9 for the last digit.	
10		To confirm Auto Off time.
<p>Instead of displaying each measurement as it is made, the Filter option displays the average of the last 16 measurements, thus reducing any fluctuations due to variations of the water conductivity at the sample point.</p> <p>The disadvantage of using the filter is that it introduces a fairly long delay when the instrument is exposed to a large and rapid change in conductivity.</p>		
11		Filter Out Filter not operating
12	 or 	Filter Out In/Out flashing. Toggle the setting to In (filter operating) or Out (filter not operating).
13	 or 	Filter In
14		Filter In Enter setting.
Press MEASURE to return to main display.		

This page is intentionally left blank

5 Fault Finding

Introduction

Note: THERE ARE NO USER SERVICEABLE PARTS INSIDE THE UNIT.

A set of error messages has been built into the system to aid fault finding and diagnosis. If one of these messages is being displayed, refer to the table at the end of this section; this lists some possible causes and suggested actions. Ensure that the error messages have not been turned off; refer to the final part of Section 4, *Error messages, auto power off and input filter*.

Fault finding hints are included below. If the fault has not been cleared after these checks have been carried out, contact LTH. Please have as much of the following information available as possible in any communication with LTH, to enable a quick repair or diagnosis of the problem to be made:

- Serial number of the instrument.
- The approximate date of purchase.
- Details of the programme settings and application. Software issue number (shown during the power up initialisation routine).
- Electrical environment and supply details.
- Circumstances under which failure occurred.
- The nature of the fault or faults.
- Any error messages that were displayed.
- The sensor type, cable length and serial number.
- Voltage output monitoring and cable lengths.

Faults

Instrument appears dead

1. Check that batteries are fitted and have correct polarity. Try using the battery charger to power the instrument.
2. Remove batteries for a few seconds, then replace them and switch on. This checks that a programme latch-up has not occurred.

Instrument display appears to malfunction

1. Switch off (or remove batteries) and on again. Check that the display shows full blocks for five seconds, followed by the Software Issue number.
2. If the fault remains, repeat the operation a couple of times.

Unable to program the instrument

Check that the software security switch is set to Out.

Membrane switch panel appears to malfunction

1. Check that the software security switch is set to Out.
2. Check that the tactile membrane key switches are 'popping'.

Conductivity reading appears incorrect

Refer to Appendix A.

1. Low conductivity due to incomplete immersion of cell electrodes or air bubbles within the cell.
2. High conductivity readings caused by a short circuit within the cell moulding. The cell should be checked, when dry, with an ohmmeter. The resistance should be greater than $50M\Omega$. See 9 way D-connector details in Section 2.
3. High conductivity can be caused by accumulation of trapped air or gas coming out of solution. Check that no "air traps" exist in the cell installation.
4. High conductivity readings caused by leakage of solution into the terminal housing. This indicates that the cell material has been fractured and the cell must be replaced.
5. Firstly check that the temperature reading is correct, otherwise the temperature compensation software will cause false or erratic readings.

Temporarily switching out the temperature compensation can help to show if this is the cause of the problem.

6. If another sensor is available, this can be used to determine whether the fault lies with the instrument or the sensor.
7. Check that the temperature compensation base temperature is set correctly to 20°C or 25°C, as required.
8. Check that the sensor cable is not damaged or broken and that the screen does not make contact with any other terminals or metal work. Under no circumstances should it be connected to the ground.
9. Check that the sensor cable is sufficiently distant from power cables or electrical noise sources.
10. Check that the correct cell constant has been selected.
11. Check that the correct range has been selected.
12. Check that the temperature compensation has been switched in if required, and that the temperature slope has been set to a sensible value for the application.
13. Check that the sensor cable is under the maximum specified length (25m).

Temperature reading appears incorrect

1. Check that the sensor is at the temperature indicated. Allow a minute or two for the sensor to stabilise.
2. Check the solution temperature by an independent method, eg. a mercury and glass thermometer.
3. If another sensor is available, this can be used to determine whether the fault lies with the instrument or the sensor. A few minutes should be allowed for stabilisation of the temperature element.
4. Measure the resistance of the temperature sensor (see 9 way D-connector details in Section 2). It should be about 1000 Ω at 0°C to 1385 Ω at 100°C.
5. Check that a wire has not become loose in a junction box or in the terminal block.
6. Check that a full 4 wire method has been used to connect the Pt1000 to the instrument. (LTH cables are always configured to this method).

Voltage outputs appear incorrect or noisy

1. Check that the load resistance is not less than 10K Ω .
2. Check that the plug and cable is not broken or damaged (see 9 way D-connector details in Section 2).
3. If a junction box is used, check that it has been wired correctly.
4. Check that the cable is not too close to power cables, contactors, motors etc.
5. Check that screened cable or twisted-pair wiring has been used for the output connections in electrically-noisy environments.
6. Check that the voltage output operating ranges have been set up correctly.

Error messages

Error messages are generated when a system fault occurs, when the instrument is incorrectly programmed by the user, or when the normal limits of operation are exceeded.

The messages will show in the bottom right hand corner of the main display, provided they have not been turned off (see page 4-10). Normal operation of the instrument will continue in most cases.

If more than one error occurs at any time, the unit will display the error message with the lowest numerical value. When an error message is displayed it is therefore possible for other errors to have occurred. Although the instrument is capable of operating with some (for example Er25), it is not advisable to let this situation persist as it may hide other more important and harmful messages.

General

Error	Description	Action/Explanation
Er01	Main input saturation.	Solution conductivity/resistivity is too high, for the selected range, or is at an extreme of temperature. See the appendices for details.
Er02	Main input saturation.	Solution conductivity/resistivity is too low, for the selected range, or is at an extreme of temperature. See the appendices for details.
Er03	Temperature sensor open circuit or above 110°C.	Check probe temperature, connections and sensor
Er04	Temperature sensor short circuit or below -10°C.	Check probe temperature, connections and sensor.
Er05	Main measurement overrange.	As for Er01. Can also be displayed during Auto range changing, as a result of a large change in measurement. This will clear in a short period of time.
Er06	Main measurement underrange.	As for Er02.
Er07	Excessive system temperature compensation.	Check temperature compensation slope and solution temperature. See the appendices for details.
Er08	Reserved for future expansion.	
Er09	Reserved for future expansion.	

System setup and operations

Error	Description	Action/Explanation
Er11	Instrument range corrupted.	Check units and operating range.
Er12	Instrument units corrupted.	Check units and operating range.

Conductivity/resistivity voltage output operations

This is only available when the Output option is fitted.

Error	Description	Action/Explanation
Er21	Measurement units do not match output units.	Set output range, zero and span.
Er22	Voltage output zero greater than or equal to voltage output span (all ranges).	Ensure zero is less than span, and span is less than instrument range fsd.
Er23	Voltage output span less than 10% of (fixed range) fsd.	Increase voltage output span or decrease instrument range.
Er24	Conductivity/resistivity less than the programmed voltage output minimum. *	Set zero lower if required, but the instrument can operate in this condition if necessary.
Er25	Conductivity/resistivity greater than the programmed voltage output maximum. *	Set span higher if required, but the instrument can operate in this condition if necessary.

* The unit may be used in situations where the conductivity/resistivity periodically goes outside the limits.

Temperature voltage output settings

This is only applicable when the output option is fitted.

Error	Description	Action/Explanation
Er31	Voltage output zero setting is greater than span setting.	Check zero and span settings.
Er32	Voltage output span is less than 10% of full-scale.	As for Er31.
Er33	Temperature is less than voltage output zero.	As for Er31.
Er34	Temperature is greater than voltage output span.	As for Er31.

Analogue calibration operations

Error	Description	Action/Explanation
Er41	Conductivity/resistivity zero at limit.	Fault in calibration data. Return to factory or call service engineer.
Er42	Conductivity/resistivity span at limit.	As for Er41.
Er43	Temperature zero at limit.	As for Er41.
Er44	Temperature span at limit.	As for Er41.

Floating-point mathematical routines

Error	Description	Action/Explanation
Er51	Overflow error.	Internal maths computation fault. Check operating conditions first.
Er52	Underflow error.	Internal maths computation fault. Check operating conditions first.
Er53	Divide by 0 error.	Internal maths computation fault. Check operating conditions first.
Er54	Too large for conversion error.	Internal maths computation fault. Check operating conditions first.
Er55	Too small for conversion error.	Internal maths computation fault. Check operating conditions first.

EEPROM checksums

Error	Description	Action/Explanation
Er61	Checksum A error detected.	Data corrupted. Check range, units, cell constant, temperature compensation settings, auto time, output range and units, security, filter setting and error message setting.
Er62	Checksum B error detected.	Data corrupted. Check output zero and span settings.
Er63	Checksum C error detected.	Fault in calibration data. Return to factory or call service engineer.
Er64	Checksum D error detected.	As for Er63.
Er65	Memory write out of range.	As for Er63.

6 Guarantee and service

Products manufactured by LTH Electronics Ltd are guaranteed against faulty workmanship and materials for a period of three years from the date of despatch, except for finished goods not of LTH manufacture, which are subject to a separate agreement.

All cells made by LTH are thoroughly tested to their published specification before despatch. As LTH have no control over the conditions in which their cells are used, no further guarantee is given, although any complaints concerning their operation will be carefully investigated.

Goods for attention under guarantee (unless otherwise agreed) must be returned to the factory carriage paid and, if accepted for free repair, will be returned to the customer's address free of charge. Arrangements can also be made for repair on site, in which case a charge may be made for the engineer's time and expenses.

If any services other than those covered by the guarantee are required, please contact LTH direct.

Note: Overseas users should contact their LTH agent. Special arrangements will be made in individual cases for goods returned from overseas.

This page is intentionally left blank

Appendix A

Cell positioning, flow rate and sampling

This is a summary of ASTM D5391-99, combined with LTH application notes.

Pure water conductivity or resistivity must be measured with a cell and temperature sensor in a flowing, closed system to prevent trace contamination from wetted surfaces and from the atmosphere.

Specialised temperature compensation can be used to correct the measurement to a reference temperature of 20 or 25°C taking into account the temperature effects on the ionisation of water, the contaminants and interactions between the two.

The cell constant for the precision cell has been determined with a secondary standard cell that has a cell constant determined by ASTM D1125-95.

Conductivity or resistivity can be used for detecting trace amounts of ionic contaminants in water. It is the primary means of monitoring the performance of demineralisation and other high purity water treatment operations.

It is used to detect ionic contamination in boiler waters, microelectronics rinse waters, pharmaceutical process waters and to monitor and control the level of boiler and power plant cycle treatment chemicals.

Exposure of the sample to atmosphere will cause changes in the conductivity/resistivity due to loss or gain of dissolved ionisable gases. CO₂ can reach an equilibrium concentration in water of about 1 mg/l and **add up to** 1 µS/cm to the conductivity due to the formation of carbonic acid. This process is quite fast, depending upon conditions.

Cell, flow chamber and sample line surfaces will slowly leach trace ionic contaminants, evidenced by increasing conductivity readings with very low or zero flow rate. There must be sufficient flow to keep these contaminants from accumulating to the point where they can significantly affect the measurement. The high and convoluted surface of platinised cells precludes their use for high purity measurements for this reason.

Samples containing dissolved gases must have sufficient flow through the cell so that bubbles cannot accumulate and occupy sample volume within the cell, causing low conductivity (high resistivity) readings.

High purity conductivity measurement must not be made on a sample downstream of pH sensors due to the possible contamination of the sample with traces of reference electrolyte salts. Use a dedicated sample line or place the conductivity cell up stream from the pH sensors.

Conductivity cells mounted downstream from ion exchangers are vulnerable to catching ion exchange resin particles between the cell electrodes.

Resin particles are sufficiently conductive to short circuit the cell and cause high off scale conductivity or extremely low resistivity readings.

Resin retainers must be effective and the cell must be installed so that it is accessible for cleaning. If this is a problem with the CMC26/001/PT43 cell use the CMC34/001/PT43 which has wider spaced electrodes of greater than 1.5mm. This has been found to be less likely to trap such particles.

Conductivity cells if subjected to demineraliser regeneration reagents require excessive rinse time to obtain satisfactory results, therefore, locate the cell where it will be isolated during regeneration. The cell should not be used to measure high ionic content samples of greater than 20 $\mu\text{S}/\text{cm}$ (less than 0.05 $\text{M}\Omega\cdot\text{cm}$) since it can retain ionic contaminants and require excessive rinse down time for valid measurements.

Cell extension cable can be added to the standard length of 2 metres up to a maximum of 5 metres. The instrument incorporates an electronic guard to minimise the effect of cable capacitance and a 4 wire temperature measurement system to allow accurate measurements with long cell connection cables. LTH 54G cable must be used to ensure correct operation.

The cell must be located in an active flowing part of the piping. Stagnant areas or dead legs must be avoided to ensure a representative sample and prevent any bubbles from adhering to the cell surfaces.

Sample lines must be designed to maintain sample integrity. Do not expose the sample to atmosphere to prevent absorption or loss of gases, particularly CO_2 which will affect conductivity.

The sample should be continuous at a stable flow rate of at least 100ml/min and should be maintained to enable sample line wetted surfaces to reach equilibrium with sample conditions. Do not make measurements following changes to sample flow rate for the period of time required to recover from transient effects on the particular sampling system.

Appendix B

Calculating the temperature coefficient of a solution

If the temperature coefficient of the solution being monitored is not known, the *AquaCal 2000* can be used to determine that coefficient. You should set the *AquaCal 2000* to auto ranging, with the temperature compensation IN and the temperature coefficient to 0.0%.

The following measurements should be done as near to the normal operating point as practical, between 5°C and 70°C for the highest accuracy. Ensure that the cell is in-line with a flowing sample. Allow the temperature sensor sufficient time to stabilise, approximately two or three minutes, and then record both the temperature and conductivity readings. Raise the solution temperature by at least 10°C and again record the temperature and conductivity readings. Using the following equation, the temperature compensation slope can be calculated in percentage terms:

$$\alpha = \frac{(G_x - G_y) \times 100\%}{G_y(T_x - 25) - G_x(T_y - 25)}$$

Note: If base temperature is set to 20°C, then replace 25 with 20 in the above equation.

Term	Description
------	-------------

G _x	Conductivity in µS/cm at temperature T _x
----------------	---

G _y	Conductivity in µS/cm at temperature T _y
----------------	---

Note: One of these measurements can be done at ambient temperature.

Programme this compensation slope value into the *AquaCal 2000*. The temperature compensation is now set up for normal operation.

If it is difficult or impossible to evaluate the temperature compensation slope using this method, a 2.0%/°C setting will generally give a good first approximation until the true value can be determined by independent means.

This page is intentionally left blank

Index

A

Accuracy	1-4
Ambient temperature	1-4
Aquacal Settings, viewing	3-2
Atmospheric effects	A-2
Auto off setting	3-3
Auto power off	1-5, 4-10
Auto power off time	1-3

B

Battery	1-5, 5-2
Battery charger	2-1

C

Cabling	2-1, 5-3
Calibration, traceable	1-1
Carbonic acid	A-1
Cell adaptor cable	2-1
Cell constant	1-1, 1-4, 2-1, 3-2, 4-6, A-1
Cell extension cable	A-2
Cell K	1-2
Cell positioning	A-1
Cells	2-1
Conductivity	1-4, 5-2
Conductivity output	4-9
Connections	2-1

D

Demineraliser regeneration	A-2
Dimensions	1-5
Display fault	5-2
Dissolved gases	A-1

E

EMC	1-5
Error messages	5-1, 5-4
Error messages flag	1-3
Error messages setting	3-3, 4-10

F

Fault finding	5-1
Filter setting	3-3
Flow chamber	2-1
Flow rate	A-1

G

Guarantee	6-1
-----------	-----

I

Input filter	1-3, 4-10
Ion exchangers	A-2
Ionization of water	A-1

K

Key pressing	3-1
--------------	-----

L

Linearity	1-4
Low battery	1-5

M

Measure button	1-2
----------------	-----

O

On/off button	1-2
Operating frequency	1-4
Operation	3-1
Output	1-2, 1-3, 1-5, 3-2, 4-7

P

pH Sensors	A-1
Power supply	2-1
Programming	5-2

R

Range	3-2, 4-2, 4-4, 5-3, 5-6
Range units	1-2
Ranges	1-4
Repeatability	1-4
Resin particles	A-2
Resistivity	1-4
Resistivity output	4-9

S

Sampling	2-1, A-1
Saturation of input	5-5
Security code	3-3, 4-1
Service	6-1
Setting up	4-1
Specification	1-4

T

Temperature	1-4
Temperature compensation	1-4, 3-2, 4-5, A-1
Temperature output	4-7
Trace contamination	A-1
Traceable calibration	1-1
Traceable standards	1-1

U

Units	3-2, 4-2, 5-6
-------	---------------

V

Voltage outputs wiring (see also Output)	2-4, 2-5, 2-6
---	---------------

W

Weight	1-5
--------	-----



AQUACAL 2000

Quick Reference

Press ON/OFF to turn the AquaCal 2000 on (and off).





Press MEASURE to display conductivity and temperature.

Setting security

To prevent tampering with parameters, the AquaCal 2000 can be locked. To lock or unlock the settings, press  and  together. Enter the code '1582' and set security to IN to enable or OUT to prohibit setting. If security is IN, the user will be unable to change any settings, although viewing is possible.



Standard setting procedure

A common procedure is used for altering settings and entering numbers, as follows:

- 1 Press  or  to start the first setting/digit flashing.
- 2 Subsequent presses will increment or decrement the setting/digit.
- 3  selects the setting/digit and scrolls to the next setting/digit.
- 4 When the last setting/digit is flashing,  enters the setting/digit and clears the flashing.
- 5 Press  to scroll onto the next display, if applicable.
- 6 Press MEASURE to return to the main display. Pressing MEASURE before entering the final setting/digit will 'escape' back to the main display without changing the settings.

Range/Units

Press RANGE/UNITS. If units are correct, use the Standard setting procedure to set the range as required. The Auto option gives automatic range changing.

If units are not correct, press  then . Use the Standard setting procedure to set the Units. Having set the Units, you can now select the required range.

Temperature compensation

Press TEMP COMP. This is used to alter or view the temperature compensation settings. The first choice is between IN and OUT. If OUT is

selected, no further setting is required. If IN is selected, the base temperature has to be set (20°C or 25°C). The next setting is slope, which is adjustable between 0.0%/°C and 3.9%/°C.

Cell constant

Press CELL K. The cell constant can be set between 0.00900 and 0.01100 0.01000 ± 10%). Only the last four digits are adjustable. If an illegal setting is attempted (e.g. 0.01200), the last legal setting will be retained and displayed.

Output

Press OUTPUT. This allows setting of the voltage outputs. Choose Cond or Temp.

- a) For COND, output range is displayed. Choose output range by scrolling through the options, before adjusting the zero and span settings in the usual manner.
- b) If TEMP is selected the zero and span settings will be displayed. Adjust zero and span in the usual manner.

Error messages, auto power off and input filter

Press MEASURE and  simultaneously.

- a) Error messages can be set to IN (displayed) or OUT (not displayed).
- b) Auto power off can be set to YES or NO. If YES, choose time.
- c) The filter can be set to IN or OUT. With filter set to IN, conductivity is averaged out over a few seconds.

LTH Electronics Ltd

Chaul End Lane
Luton
Bedfordshire
LU4 8EZ
United Kingdom

Telephone : +44 (0) 1582 593693

Fax : +44 (0) 1582 598036

e-mail : sales@lth.co.uk

web : www.lth.co.uk